

# Thin Gage Silicon-Iron

for

## Motors, Generators, Transformers and Inductors

Steve Constantinides, Director of Technology  
Arnold Magnetic Technologies  
Freiberg, Germany, 10.06.11

**UK Magnetic Society**



*Our world touches your world every day...*

1

- Demand for electrical device efficiency gains which started decades ago due to economic factors have accelerated, propelled by the unprecedented rise in energy costs and the alleged impact of energy consumption on global weather instability.
- Thin gage silicon-iron products, both grain-oriented and non-grain oriented, such as Arnold's Arnon™ offer substantial advantages in many applications.

## Agenda

- Introduction
- GOES versus NGOES
- Motor & Transformer Efficiency
- Loss Factors
- NGO Thin Gauge (Arnon)

This presentation is an extended version of the paper to be published as part of this conference. This will be available, along with the speaker notes, for downloading from the Arnold website at [www.arnoldmagnetics.com/mtc/tech\\_presentations.htm](http://www.arnoldmagnetics.com/mtc/tech_presentations.htm)



*Our world touches your world every day...*

2

- Over the last several years I've spoken about permanent magnets. However, the magnetic material that is utilized in far greater tonnage than magnets is the family of soft magnetic materials, especially Silicon-Iron whose usage spans both motor/generator and transformer/inductor applications.
- Often referred to as Electrical Steel, Silicon-Iron (Si-Fe) is available in both Grain Oriented (GOES) and Non-Oriented (NGOES) forms.

## Who is Arnold?

- Arnold Magnetic Technologies Corp. is one of the largest manufacturers and suppliers of magnetic materials
- Our headquarters and 5 manufacturing locations are in the USA, but we have a global presence with operations in Switzerland, the United Kingdom and China
- Our products include both permanent and soft magnetic products and assemblies
- The Rolled Products Division has been in operation since the early 1960's and specializes in thin gage alloy strip and foil
  - Thin meaning from 0.007" down to less than 0.000085"
  - Super efficient Si-Fe is available in thicknesses from 0.007" down to 0.001"

Visit the Arnold website to learn more about our products!  
Find out how we can help you achieve your product performance goals.



*Our world touches your world every day...*

3

- First let's introduce Arnold Magnetic Technologies.
- Arnold started as a privately owned manufacturer over 100 years ago in northern Illinois.
- The founder, Bion Arnold, was a world famous electrical engineer and inventor. His son, Robert, took over the running of the company from the 1940's until the late 1960's.
- In the 1950's, Arnold was sold to Allegheny Steel Company (Allegheny Ludlum, Allegheny International) and remained part of Allegheny until 1986.
- It was during the Allegheny ownership period that Arnold developed its rolling mill capabilities and many of the electrical steel grades such as Arnon™ 5 and Arnon™ 7.
- Product development continued and today Arnold's Rolled Products Division provides the highest available quality strip and foil in dozens of materials, both magnetic and non-magnetic.

## Arnold's Knowledge Base

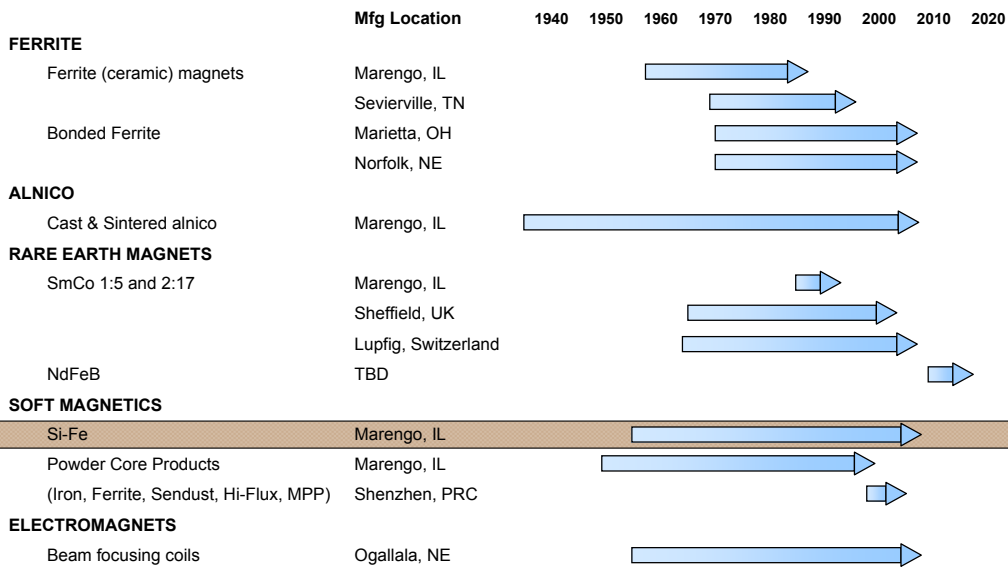

Our world touches your world every day...

- Over the last 70 years, Arnold has developed an extensive knowledge base in a wide range of materials including, but not limited to those shown here.
- As products and markets have changed, Arnold's product line-up and manufacturing locations have adapted.

## Two Main Applications for Electrical Steel

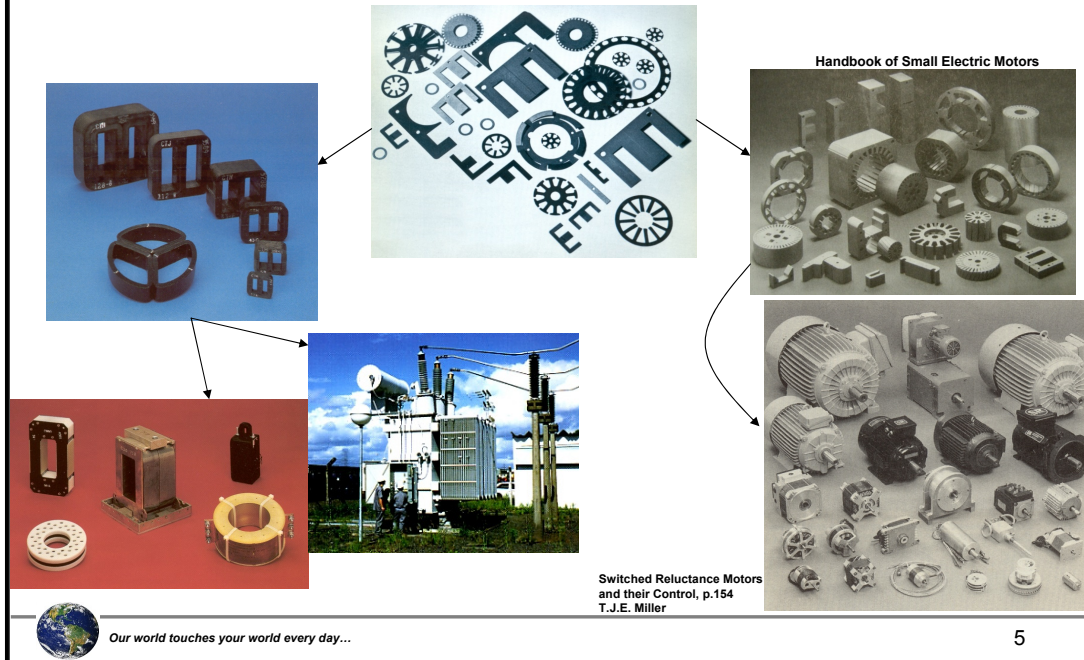

- As you are likely aware, there are two major uses for Electrical Steel: Transformers/Inductors and Motors/Generators.
- Transformers are used not only for Electrical Power Distribution, but in virtually every power supply in every electrically powered electronic device in offices and homes.
- Motors have moved from industrial uses in the 1800's and early 1900's to home and automotive uses. In homes for example, we use motors in garage door openers, washing machines and dryers, furnaces for home heating, refrigerator compressor pumps, bathroom exhaust fans, garbage disposals, and electric powered shop tools.
- Motor usage in automobiles has expanded to include windshield wiper motors, seat adjusting motors, starters, cooling fans, passenger compartment fans, alternators, etc. Note however, many of these use low carbon steel cans for low cost with laminations reserved for higher output, higher efficiency motors/generators.
- The newest example of lamination steel use in cars is the electric drive motor of hybrids or full electric vehicles.

## Agenda

- Introduction
- GOES versus NGOES
- Motor & Transformer Efficiency
- Loss Factors
- NGO Thin Gauge (Arnon)



- Let's briefly examine the structure of grain oriented and non-oriented silicon-iron.

## Understanding the Structure

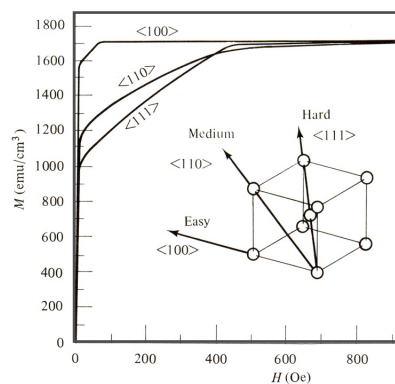

Magnetization curves for single crystals of iron (by Honda and Kaya)

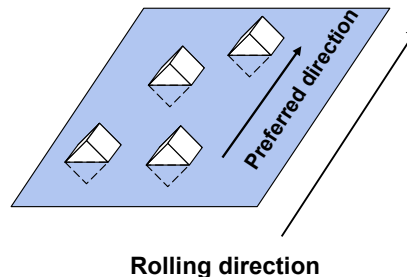

Norman P. Goss (February 4, 1906 – October 28, 1977) was an inventor and researcher from Cleveland, Ohio, USA. He graduated from Case Institute of Technology in 1925. He made significant contributions to the field of metals research, and in 1935 he published a paper[1] and patented a method[2] to obtain so-called grain-oriented electrical steel, which has highly anisotropic magnetic properties. This special "grain-oriented" structure was named after its inventor and it is referred to as the "GOSS structure". Grain-oriented electrical steel enabled the development of highly efficient electrical machines, especially transformers. Today, the magnetic cores of all high-voltage high-power transformers are made of grain-oriented electrical steel. -- Wikipedia



Our world touches your world every day...

7

- By the 1940's it was well known that the iron single crystal has a preferred direction along which magnetization is easier.
- This Goss Structure, named after Norman Goss, translates to higher permeability and lower core loss in that given direction, the "cube-on-edge" direction.
- It was recognized that if all the grains in a lamination can be aligned this way, the lamination can be cut to take advantage of this performance enhancement.
- This structure and process were developed to create the preferred orientation in the rolled silicon steel strip. The process involves a combination of cold working and heat treating to produce a strip where most of the metal grains are oriented along the rolling direction.
- While the material is not uniform in all directions, many components such as wound cores and stamped/stacked E cores can be made to maximize the positive aspects of orientation.
- As shown in the illustration at the left, the easy axis (of magnetization) is along the <100> crystal axis.
- The "hard" axis is from one corner to the diagonally opposite corner: the <111> crystal axis.
- To reiterate, effective application of the material requires using the strip in the same direction that flux is expected.

## GOES Texturing

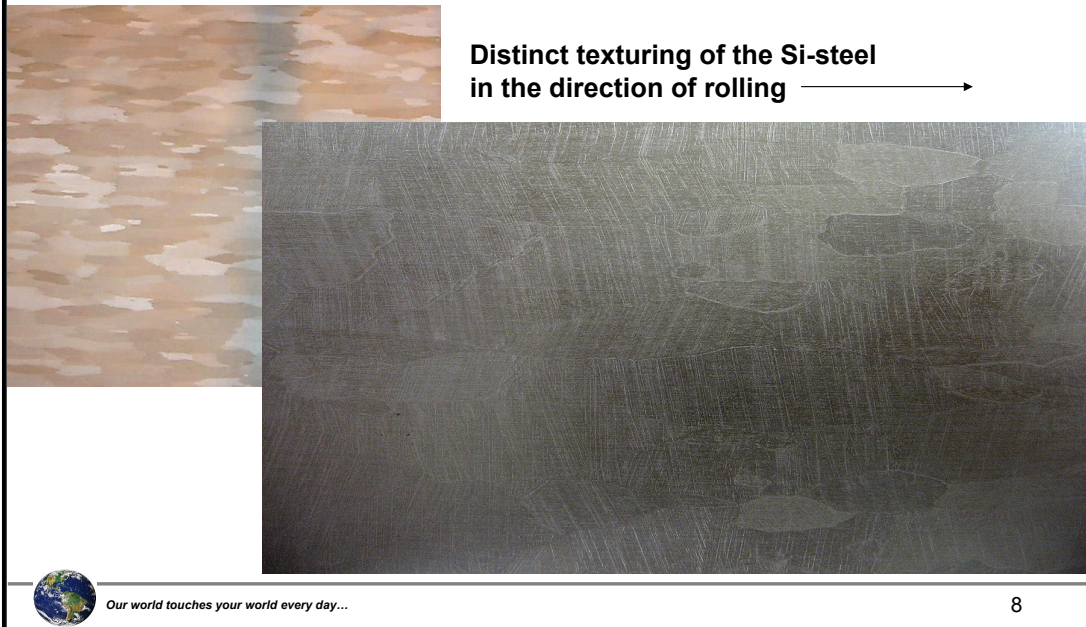

- Silicon-Iron consists of BCC (body-centered cubic) crystals which, during rolling, are stretched and flattened. If they are left in that state, the magnetic properties are maximized but only in the rolling direction, that is along the length of the strip.
- In these two photos we can see the elongated and flattened structure of Grain Oriented Electrical Steel (GOES).



## Directional Properties of Si-Steel (GOES) - Bozorth

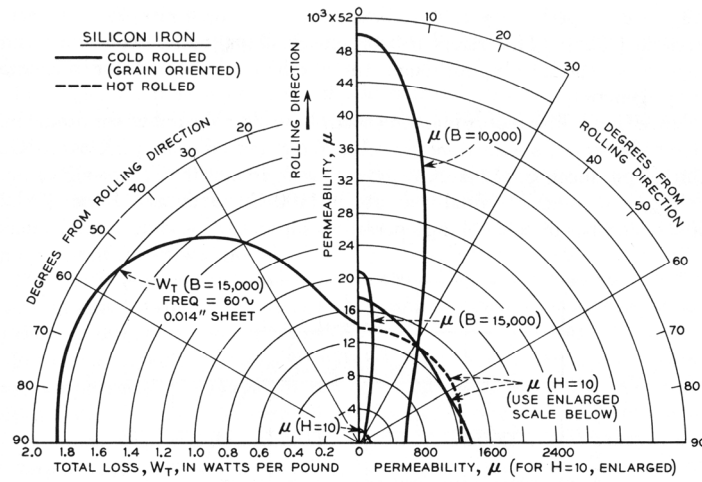

FIG. 4-21. Dependence of permeability and losses of hot rolled and grain-oriented sheet on direction of measurement in sheet.



Our world touches your world every day...

- Bozorth presents this information on the affect of rolling direction on magnetic properties.

## Directional Properties of Si-Steel (GOES) – AK Steel

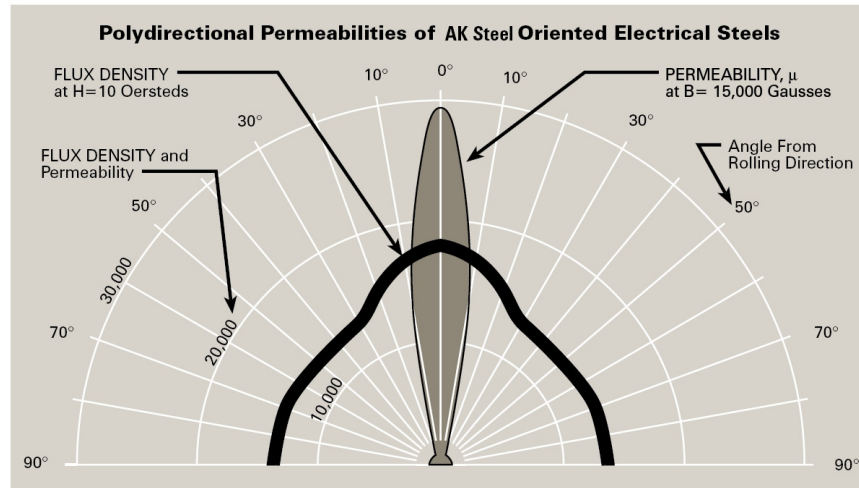

Figure 3. Tests made on Epstein samples cut at various angles to rolling direction, stress annealed after shearing. Negligible joint effects. Assumed density 7.65 grams per cubic centimeters.



Our world touches your world every day...

- This simpler chart from AK steel for grain oriented silicon iron illustrates the difference in magnetic properties in the rolling direction (straight up and down) and at angles at up to 90° from the rolling direction (left to right).
- Maximum performance is achieved by application of the material with the strip in the same direction that flux is expected.
- In contrast, NGOES shows only a 10-20% variation in properties within the plane of the strip.

## GOES versus NGOES

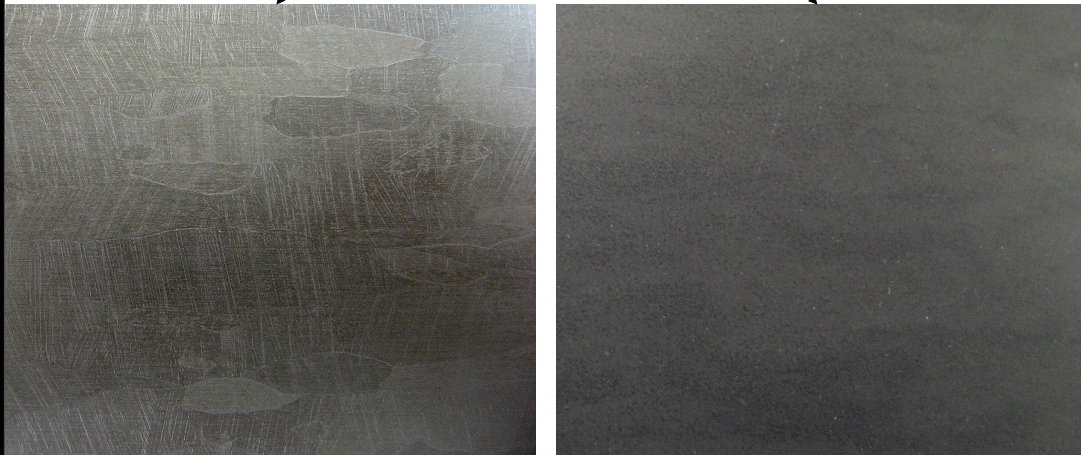

*Our world touches your world every day...*

11

- When a final annealing heat treat is performed, nearly isotropic properties are achieved within the plane of the strip.
- This is exemplified by the almost total elimination of the grain structure as seen in the photo to the right.

## Silicon-Iron Manufacturing Steps

1. Melting and continuous casting of slabs
2. Hot Rolling to thickness of ~2 mm
3. Pickling and cold rolling to intermediate gauge
4. Annealing (750 to 900 °C)
5. Cold rolling to final gauge (0.13 – 0.35 mm)
6. Decarburization and re-crystallization anneal (830 – 900 °C)
7. Final anneal (850 – 1100 °C) - - for NGOES
8. Coating (washing, coating, drying)
9. Slitting
10. Punching or laser-cutting to shape



- These are the typical manufacturing steps and utilize equipment such as melting furnaces, hot and cold rolling mills, atmosphere treatment furnaces, acids and inorganic coating materials, tool steel precision slitters, etc.
- In defense of the manufacturers, the process for making lamination-ready Si-Fe strip involves many processing steps and utilizes expensive manufacturing equipment.

## Sendzimir Mill Rolling to Final Gauge

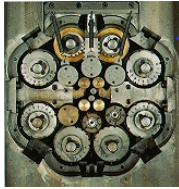

Sendzimir mill roll arrangement  
Side view

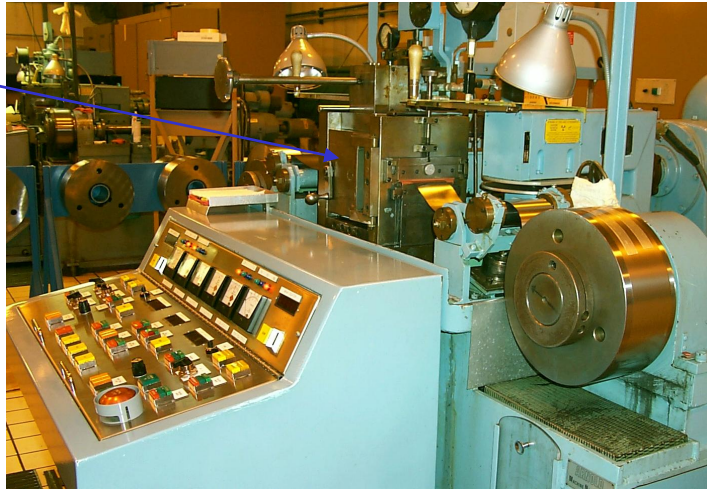

[www.sendzimir.com](http://www.sendzimir.com)



*Our world touches your world every day...*

13

- For thin gauge, specialized rolling mills are used to achieve uniform cross-strip thickness and flawless surfaces on Si-Fe down to 0.001" (0.025 mm).
- Arnold does, incidentally, roll other alloys to less than 85 millionths of an inch (0.000085" or 0.0022 mm, 2.2 microns) on Sendzimir mills.
- The Sendzimir mill uses small diameter rolls to reduce the strip thickness. The small rolls are backed-up by larger rolls to eliminate bending of the small rolls under intense compressive stress.
- The use of small diameter inner rolls is required to apply the very high contact pressures required to compress the sheet thickness while it is being stretched by the powerful drive and take-up motors.

## Agenda

- Introduction
- GOES versus NGOES
- Motor & Transformer Efficiency
- Loss Factors
- NGO Thin Gauge (Arnon)



- Reduced eddy current loss in thin gage lamination materials such as Arnold's grades (between 0.001 and 0.007" thick, 0.025 to 0.178 mm) permit higher frequency operation and lower losses.
- Silicon-Iron laminations are more expensive than low carbon steel and their use has been reserved for high energy density, high rpm motors and generators and for high frequency transformers.

## Motor Efficiency

“...~57% of the generated electric energy in the United States is utilized [consumed] by electric motors powering industrial equipment. In addition, more than 95% of an electric motor’s life-cycle cost is the energy cost.”

The Next Generation Motor, IEEE Industry Applications, January / February 2008, p.37



*Our world touches your world every day...*

## Electric Operating Cost

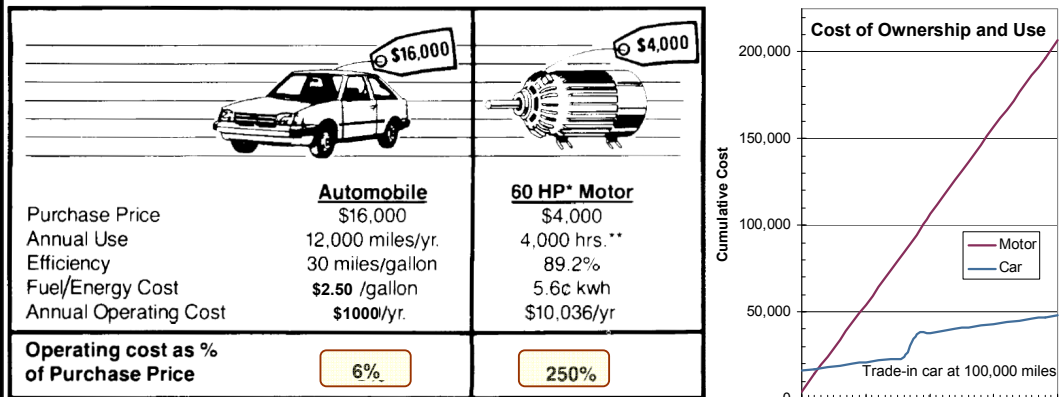

**Figure 1. First Cost is not the Last Cost**

\*60 HP; equivalent to 50.18 kW capacity

\*\*Based on 2-shift operation

Art courtesy of Ontario Hydro

From AEC (North Carolina Alternative Energy Corporation), updated with current gas prices, [www.p2pays.org/ref/17/16897.pdf](http://www.p2pays.org/ref/17/16897.pdf)



Our world touches your world every day...

- This chart is from the Alternative Energy Corporation (AEC) and has been updated with recent U.S. gasoline pricing.
- Electric costs are typical.
- It is obvious that more consideration must be paid to total operating costs, not just initial purchase price.
- Our industry needs to help educate customers to consider more than just initial purchase price.



## Opportunities for Efficiency Improvement

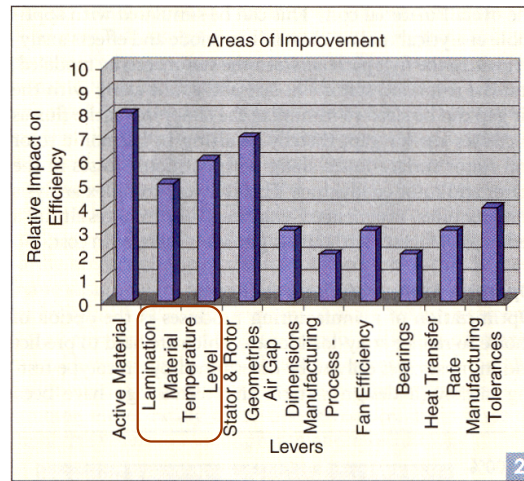

Impact of the possible areas of improvement for the performance of induction motors.



- Efficiency increase is affected by many facets of the motor.
- With targets of 96% plus efficiency, it is imperative to optimize lamination material.
- “Lossy” material adds to heat buildup which also reduces motor life expectancy.

## Comparison of Losses

COMPARISON OF LOSS DISTRIBUTION BY PERCENT FOR MOTORS TESTED IN THE EASA/AEMT STUDY [12].

Losses	Two-Pole Average	Four-Pole Average	Design Factors Affecting Losses
Core losses ( $W_c$ )	19%	21%	Electrical steel, air gap, saturation, supply frequency, condition of interlaminar insulation
Friction and windage losses ( $W_{fw}$ )	25%	10%	Fan efficiency, lubrication, bearings, seals
Stator I <sup>2</sup> R losses ( $W_s$ )	26%	34%	Conductor area, mean length of turn, heat dissipation
Rotor I <sup>2</sup> R losses ( $W_r$ )	19%	21%	Bar and end ring area and material
Stray load losses ( $W_l$ )	11%	14%	Manufacturing processes, slot design, air gap, condition of air gap surfaces and end laminations

Increased Efficiency versus Increased Reliability, IEEE Industry Applications, January / February 2008, p.33



Our world touches your world every day...

- 20% of energy loss in the motors under this study is from Core Loss, most of which is attributed, either directly or indirectly, to the lamination material.

## Energy Consumption by Motor Size

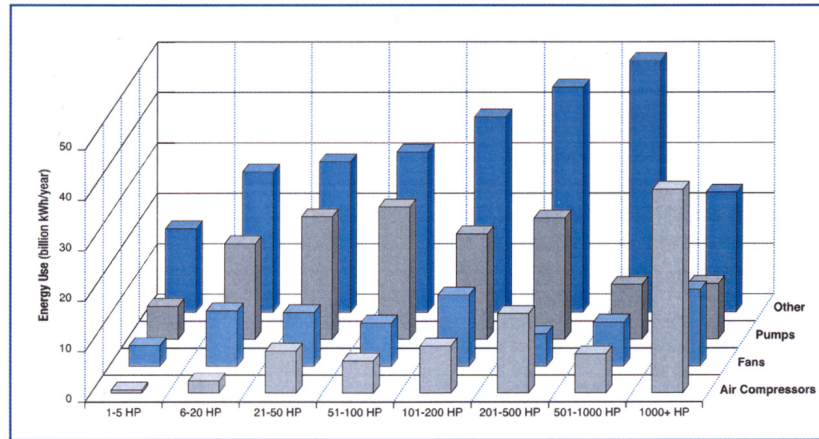

**Motor system energy consumption** (Adapted from information in the *United States Industrial Electric Motor Systems Market Opportunities Assessment*, available online at [www.eere.energy.gov/industry/bestpractices/](http://www.eere.energy.gov/industry/bestpractices/).)



Our world touches your world every day...

- Despite very large numbers of small motors in use today, large industrial motors consume greater amounts of electric power than smaller motors.
- Large industrial motors are more likely to run continuously, while smaller motors may be “on” only a small fraction of time.

## Energy Policy Act Efficiency Targets

Number of Poles	Nominal Full-Load Efficiency					
	OPEN MOTORS			CLOSED MOTORS		
	6	4	2	6	4	2
Motor Horsepower						
1	80.0	82.5	-	80.0	82.5	75.5
1.5	84.0	84.0	82.5	85.5	84.0	82.5
2	85.5	84.0	84.0	86.5	84.0	84.0
3	86.5	86.5	84.0	87.5	87.5	85.5
5	87.5	87.5	85.5	87.5	87.5	87.5
7.5	88.5	88.5	87.5	89.5	89.5	88.5
10	90.2	89.5	88.5	89.5	89.5	89.5
15	90.2	91.0	89.5	90.2	91.0	90.2
20	91.0	91.0	90.2	90.2	91.0	90.2
25	91.7	91.7	91.0	91.7	92.4	91.0
30	92.4	92A	91.0	91.7	92.4	91.0
40	93.0	93.0	91.7	93.0	93.0	91.7
50	93.0	93.0	92A	93.0	93.0	92.4
50	93.6	93.6	93.0	93.8	93.6	93.0
75	93.6	94.1	93.0	93.6	94.1	93.0
100	94.1	94.1	93.0	94.1	94.5	93.6
125	94.1	94.5	93.6	94.1	94.5	94.5
150	94.5	95.0	93.6	95.0	95.0	94.5
200	94.5	95.0	94.5	95.0	95.0	95.0

Increasing Efficiency Targets

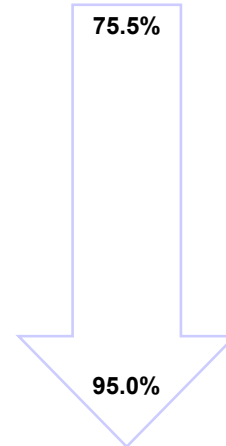

Our world touches your world every day...

- This chart emphasizes the energy efficiency requirements of higher HP motors since that is where the greatest energy savings is expected to accrue.

## Efficiency Regulations

### General Industrial Low Voltage Motors

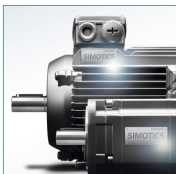
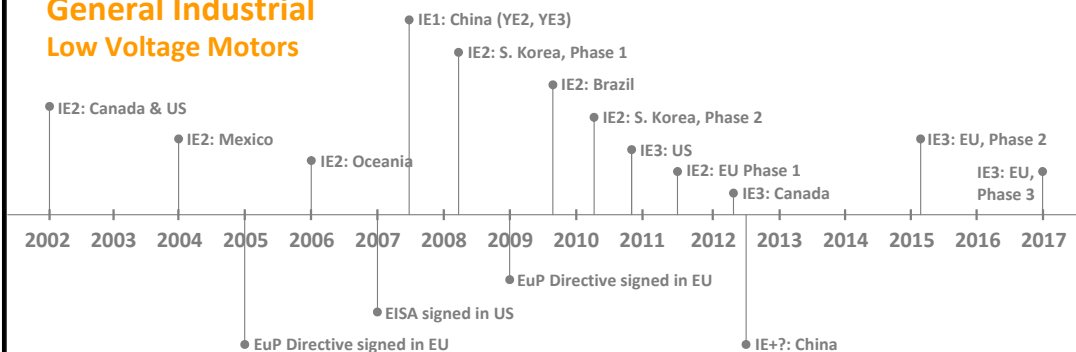

**Regulations demand increased efficiency at lower costs which pushes technology to higher power density, speed and temperatures**



Our world touches your world every day...

- Efficiency regulations are evolving – becoming more demanding.
- IE4 is in final development and will move beyond IE3.

## Additional Motor Efficiency Information

- Energy Efficient Electric Motor Selection Handbook
  - [www.wbdg.org/ccb/DOE/TECH/ce0384.pdf](http://www.wbdg.org/ccb/DOE/TECH/ce0384.pdf)
- Buying an Energy Efficient Electric Motor
  - [www1.eere.energy.gov/industry/bestpractices/pdfs/mc-0382.pdf](http://www1.eere.energy.gov/industry/bestpractices/pdfs/mc-0382.pdf)
- Consortium for Energy Efficiency
  - [www.cee1.org/ind/mot-sys/mtr-ms-main.php3](http://www.cee1.org/ind/mot-sys/mtr-ms-main.php3)
- Efficient Electric Motor Systems for Industry
  - [www.osti.gov/bridge/servlets/purl/10112522-FoENQM/webviewable/10112522.PDF](http://www.osti.gov/bridge/servlets/purl/10112522-FoENQM/webviewable/10112522.PDF)
- Efficient Electric Motor Systems: SEEEM
  - [www.asiapacificpartnership.org/BATF/BATF%20Projects%20Workshops/Motors%20WS-SEEEM-brunner.pdf](http://www.asiapacificpartnership.org/BATF/BATF%20Projects%20Workshops/Motors%20WS-SEEEM-brunner.pdf)
- Development of Ultra-Efficient Electric Motors
  - [www.osti.gov/bridge/servlets/purl/928973-hsePV1/928973.PDF](http://www.osti.gov/bridge/servlets/purl/928973-hsePV1/928973.PDF)
- Electric Motor Systems in Developing Countries: Opportunities for Efficiency Improvement
  - [www.osti.gov/bridge/servlets/purl/10187187-n23Ohm/native/10187187.PDF](http://www.osti.gov/bridge/servlets/purl/10187187-n23Ohm/native/10187187.PDF)



- There is a wealth of information on the internet. Here are just a few additional useful links.



## Transformers



Transformers can be small enough for installation onto circuit boards or as large as a house



*Our world touches your world every day...*

23

- Transformers and Inductors when used at low frequencies, such as these electric distribution transformers utilize low cost iron laminations and operate with efficiencies of 98% and higher.
- Smaller, special purpose transformers in high frequency and pulse power applications benefit from thin gauge and higher resistivity Si-Fe laminations.
- Examination of this subject would require an entire session by itself, so we will restrict this to just a few slides.

## Transformers

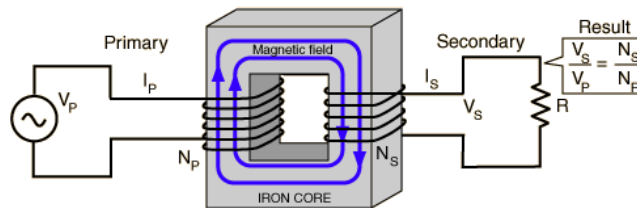

The magnetic field in a motor or generator is continuously changing orientation relative to the structure; the magnetic field in a transformer is in a fixed direction and benefits from the properties of GOES.

<http://hyperphysics.phy-astr.gsu.edu/hbase/magnetic/transcon.html#c1>



Our world touches your world every day...

24

- Transformers are used to convert lower voltages to higher voltages (step-up transformer) or higher voltages to lower ones (step-down).
- The ratio of turns of wire on the primary (input) to those on the secondary (output) determines which type it is.
- Since power stays the same, when voltage increases, current decreases - - and the converse is true.
- The applied voltage cannot be steady DC: it must change as a function of time such as AC or pulsed or varying DC.
- Each of the windings has associated with it an electrical resistance.
- Under AC (or pulsed DC) conditions, this resistance becomes inductive (inductance).
- Therefore, a Si-Fe core with only a single winding is called an inductor.



## Transformers: Examples



Photographs  
courtesy  
of ABB

From  
**Small**

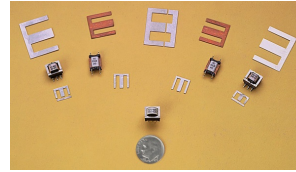

Photograph courtesy of Magnetic Metals

To  
**Large**

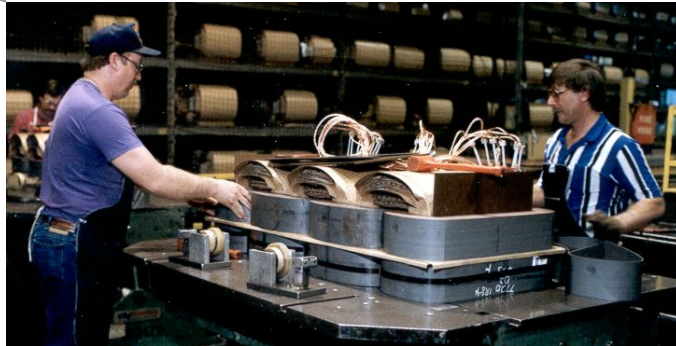

Silicon Steel 3-Phase Transformer

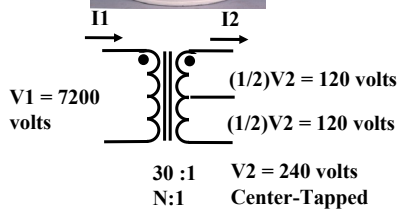

*Our world touches your world every day...*

- Transformer (and inductor) sizes vary greatly.
- The picture at the left is a typical step-down transformer which reduces power line voltages to 120/240 volts for domestic use.
- The high voltage connectors are on the top and the 120/240 volt connectors are on the side of this transformer case.

## DOE – Appliances and Commercial Equipment Standards Program

### Laws and Regulations

- The Energy Policy and Conservation Act (EPCA) of 1975 established an energy conservation program for major household appliances.
- The National Energy Conservation Policy Act of 1978 amended EPCA to add Part C of Title III, which established an energy conservation program for certain industrial equipment.
- The Energy Policy Act of 1992 amended EPCA to add certain commercial equipment, including [distribution transformers](#).



## DOE Actions on Distribution Transformers

- Energy Conservation Standard – started in 2000.
  - Framework Document Workshop, November 1, 2000
  - Draft analyses published 2001 through 2003
  - ANOPR published July 29, 2004
    - *Public Meeting, September 28, 2004*
  - EPAAct 2005 establishes standards for Dry-type Transformers effective January 1, 2007
  - NOPR, August 4, 2006
    - *Public Meeting, September 27, 2006*
  - Final Rule Published October 12, 2007
    - *Effective January 1, 2010*



## Transformer Energy Loss

- Energy loss in a transformer is almost totally converted to **heat**
- Energy loss is mostly caused by
  - Coil Loss
  - Eddy current and hysteresis loss
  - Winding resistance dominates load losses, whereas hysteresis and eddy currents losses contribute to over 99% of the no-load loss.
- Temperature rise is a rough indicator of transformer efficiency
- Transformer temperature rise is defined as the average temperature rise of the windings above the ambient (surrounding) temperature, when the transformer is loaded at its nameplate rating
  - Dry-type transformers are available in three standard temperature rises: 80C, 115C, or 150C
  - Liquid-filled transformers come in standard rises of 55C and 65C
- Transformer losses in power distribution networks can exceed **3%** of the total electrical power generated and are estimated to total **140 billion kilowatt-hours (kWh) per year in the U.S.**
  - Converting these transformers to higher efficiency units would reduce wasted electricity by about 61 billion kWh each year.



### • Winding resistance

Current flowing through the windings causes resistive heating of the conductors. At higher frequencies, skin effect and proximity effect create additional winding resistance and losses.

### • Hysteresis losses

Each time the magnetic field is reversed, a small amount of energy is lost due to hysteresis within the core. For a given core material, the loss is proportional to the frequency, and is a function of the peak flux density to which it is subjected.

### • Eddy currents

Ferromagnetic materials are also good conductors, and a solid core made from such a material also constitutes a single short-circuited turn throughout its entire length. Eddy currents therefore circulate within the core in a plane normal to the flux, and are responsible for resistive heating of the core material. The eddy current loss is a complex function of the square of supply frequency and inverse square of the material thickness.

### • Magnetostriction

Magnetic flux in a ferromagnetic material, such as the core, causes it to physically expand and contract slightly with each cycle of the magnetic field, an effect known as magnetostriction. This produces the buzzing sound commonly associated with transformers, and in turn causes losses due to frictional heating in susceptible cores.

### • Mechanical losses

In addition to magnetostriction, the alternating magnetic field causes fluctuating electromagnetic forces between the primary and secondary windings. These incite vibrations within nearby metalwork, adding to the buzzing noise, and consuming a small amount of power.

### • Stray losses

Leakage inductance is by itself lossless, since energy supplied to its magnetic fields is returned to the supply with the next half-cycle. However, any leakage flux that intercepts nearby conductive materials such as the transformer's support structure will give rise to eddy currents and be converted to heat.

## Single Phase Efficiency (%)

<u>kVA</u>	<u>NEMA TP-1</u>	<u>TSL2</u>	<u>Final Rule</u>	<u>TSL4</u>
10	98.40	98.40	98.62	98.48
15	98.60	98.56	98.76	98.63
25	98.70	98.73	98.91	98.79
37.5	98.80	98.85	99.01	98.91
50	98.90	98.90	99.08	99.04
75	99.00	99.04	99.17	99.08
100	99.00	99.10	99.23	99.14
167	99.10	99.21	99.25	99.25
250	99.20	99.26	99.32	99.45
333	99.20	99.31	99.36	99.49
500	99.30	99.38	99.42	99.54
667	99.40	99.42	99.46	99.57
833	99.40	99.45	99.49	99.60



TSL stands for Trial Standard Levels with #1 through 6.

- TSL1 = NEMA TP 1-2002 (industry voluntary standard)
- TSL2 ~1/3 of the efficiency between TP 1 and Min LCC (TSL4)
- TSL3 ~2/3 of the efficiency between TP 1 and Min LCC (TSL4)
- TSL4 ~minimum life-cycle cost (LCC)
- TSL5 ~maximum energy savings with no change in LCC
- TSL6 = maximum technologically feasible

## Three Phase Efficiency (%)

<u>kVA</u>	<u>NEMA TP-1</u>	<u>TSL2</u>	<u>Final Rule</u>	<u>TSL4</u>
15	98.10	98.36	98.36	98.68
30	98.40	98.62	98.62	98.89
45	98.60	98.76	98.76	99.00
75	98.70	98.91	98.91	99.12
112.5	98.80	99.01	99.01	99.20
150	98.90	99.08	99.08	99.26
225	99.00	99.17	99.17	99.33
300	99.00	99.23	99.23	99.38
500	99.10	99.32	99.25	99.45
750	99.20	99.24	99.32	99.37
1000	99.20	99.29	99.36	99.41
1500	99.30	99.36	99.42	99.47
2000	99.40	99.40	99.46	99.51
2500	99.40	99.44	99.49	99.53



## Agenda

- Introduction
- GOES versus NGOES
- Motor & Transformer Efficiency
- Loss Factors
- NGO Thin Gauge (Arnon)



- Si-Fe is more expensive than low carbon steel and thin gauge Si-Fe is more expensive than thick gauge.
- Si-Fe's advantage is a combination of relatively low cost with relatively high performance.

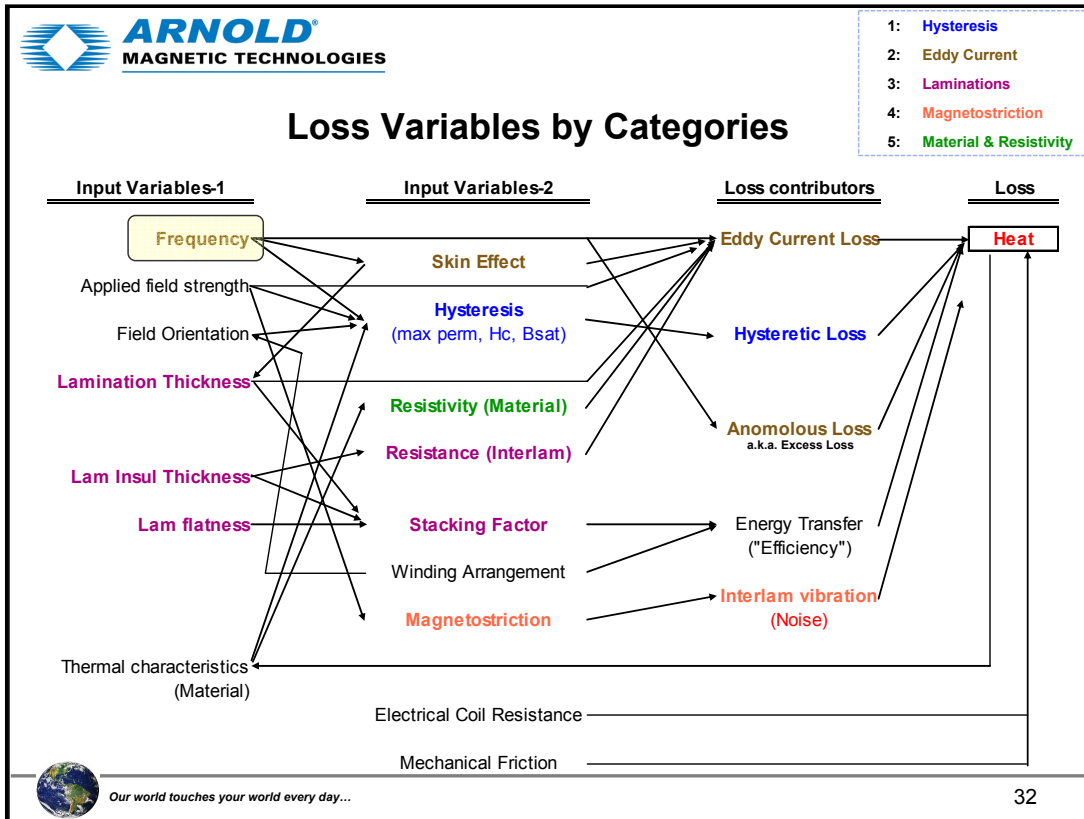









- There is a complex set of variables involved with selecting the proper soft magnetic material and thickness.
- Lower efficiency is the result of energy being converted to heat.
- Note that many of the variables are interactive. One variable can affect another variable. For example, switching frequency affects how deep the field will penetrate a lamination which affects required lamination thickness which affects stacking factor, etc.
- That is, the use of thin gauge Si-Fe (Arnon™ 5 and Arnon™ 7) can minimize the losses associated with most of these items.
- These variables can be grouped into similar categories for discussion.
- 5 groups have been created here as shown in the upper right of the chart.
- We need to first understand some basics regarding Frequency, so that will be our first topic.



## Waveforms

**Note:** In these formulas  $N$  is the number of turns in the winding across which the voltage is developed.  $A$  is the cross-sectional area of the core around which the winding is placed. If the area is expressed in square centimeters, the flux density will be in gauss. If the area is expressed in square inches, the flux density will be in maxwells per square inch. Time  $t$  is in seconds. Frequency  $f$  is in hertz. Voltage  $E$  in in volts. Current  $I$  is in amperes. Inductance  $L$  is in henries.

**Table 1.1** Maximum Flux Density Formulas for Commonly Occurring Functions

Function	Waveform	Formula
1. Sine wave voltage (steady-state)		$B_{\max} = \frac{E_{\text{rms}} \times 10^8}{4.44NAf}$
2. Symmetrical square wave voltage		$B_{\max} = \frac{E_{\text{pk}} \times 10^8}{4NAf}$
3. Interrupted symmetrical square wave voltage		$B_{\max} = \frac{E_{\text{pk}} \times t \times 10^8}{2NA}$
4. Half sine wave voltage pulse		$B_{\max} = \frac{E_{\text{pk}} \times 2 \times t \times 10^8}{\pi NA}$
5. Unidirectional rectangular voltage pulse		$B_{\max} = \frac{E_{\text{pk}} \times t \times 10^8}{NA}$
6. Full-wave-rectified single-phase sine wave voltage (ac component only)		$B_{\max} = \frac{E_{\text{dc}} \times 10^8}{19.0NAf}$
7. Half-wave-rectified three-phase sine wave voltage (ac component only)		$B_{\max} = \frac{E_{\text{dc}} \times 10^8}{75.9NAf}$
8. Full-wave-rectified three-phase sine wave voltage (ac component only)		$B_{\max} = \frac{E_{\text{dc}} \times 10^8}{664NAf}$
9. Current	Any	$B_{\max} = \frac{LI_{\max} \times 10^8}{NA}$

Handbook of Transformer Design & Application, p. 1.6



Our world touches your world every day...

- Before we begin examining magnetic and electrical properties of the material, it is necessary to understand that the affects upon the material are due to the **rate** and **magnitude** of applied field change.
- While we consider a sinusoidal wave form to be most common, developments in electronic controls over the past two decades have allowed application of complex waveforms for both control and efficiency.
- Some of these waveforms produce more rapid field changes than suggested by the over riding frequency. One example of this is a pulse field waveform.

## PWM

DRIVES AND CONTROLS

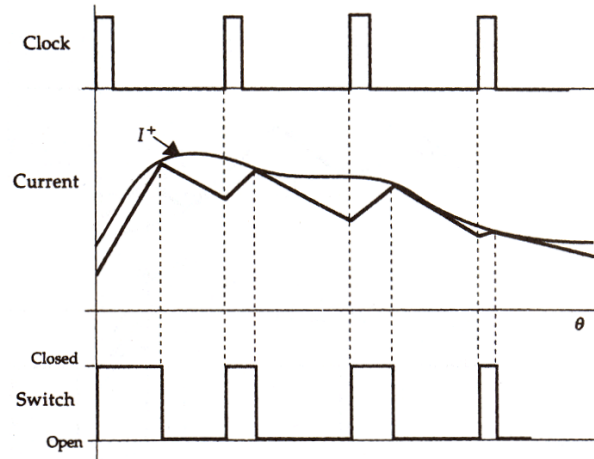

**FIGURE 10.86** Clocked turn-on PWM waveforms.

Handbook of Small Electric Motors, William H and Allan W. Yeadon



Our world touches your world every day...

- With Pulse Width Modulation, each pulse exhibits very high frequency (rapid change of electrical field).
- There are many types of PWM including: Clocked Turn on (shown here), Hysteresis, Clock Turn-Off, Dual Current Mode, and Triangle (or sinusoidal) PWM.
- The actual rate of change in current and in field is also a function of coil inductance as shown in the middle of the chart.

## 1: Hysteresis Curve

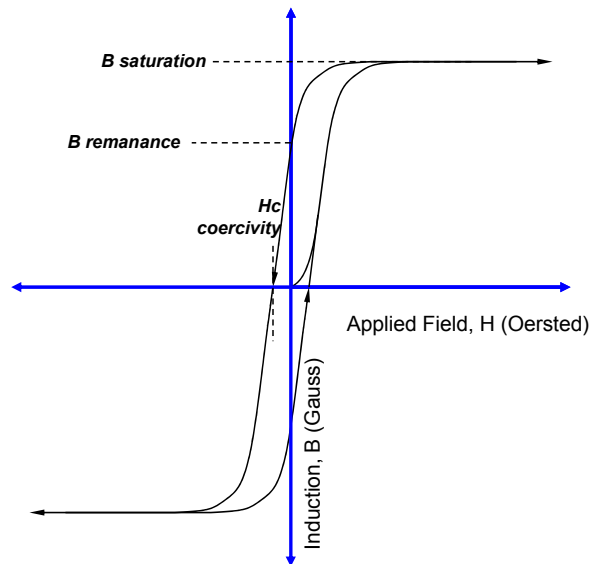

Focusing on the hysteresis curve...

- A sinusoidal magnetic field applied to a ferromagnetic material will drive an applied field (H) back and forth along the horizontal axis as shown in this hysteresis curve. As the applied field increases, the induction increases, etc.
- As it proceeds in the first quadrant, the material can become fully saturated.
- However, as the H field decreases toward the negative region (2nd quadrant), the induction does not follow the exact same path. Instead, there is a lag--or hysteresis in the induction.
- Even when the field reaches zero ( $H=0$ ), there is still some induction remaining in the material. This is called the remanant flux density, or  $B_r$ .
- To bring the induction in the material down to zero, the H field must be driven past the origin to a negative value called  $H_c$  or  $H_cB$  -- this is the "coercivity" of the material.
- As the sinusoidal field continues to go through its cycles, this behavior is repeated in both directions (polarities).

## 1: Hysteresis Loss

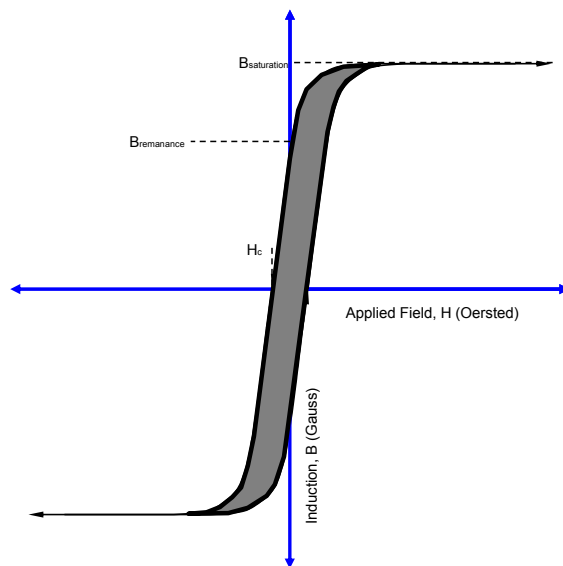

- One implied property from these hysteresis curves is that there is significant energy absorption represented by and proportional to the area inside the hysteresis curve.
- In soft magnetic applications, this energy absorption manifests itself as “hysteresis loss”.
- The hysteresis loss is the energy absorbed by the material as it being magnetized in one direction, magnetized in the reverse direction, and re-magnetized in the original direction.

## 1: Hysteresis Curve - Minor Loops

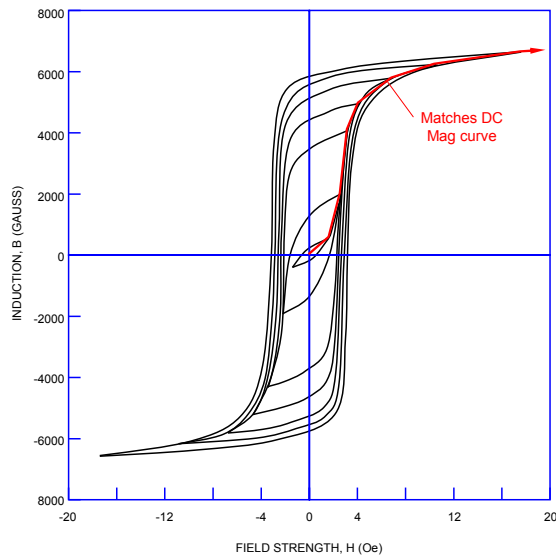

- In a PM motor, the material is not likely to be driven to saturation except on the poles.
- As a result, much of the material will be experiencing “minor” loop properties.
- This is a series of super-imposed minor hysteresis loops.
- It can be clearly seen that the induction response differs greatly depending upon the level of applied field (H).
- The energy loss will be proportional to the area within the specific minor loop experienced by each part of the lamination.
- Since not all the material will see the same externally applied field, there will be unequal energy loss from place to place within the lamination structure.

## 1: Hysteresis Loss - Frequency Effects

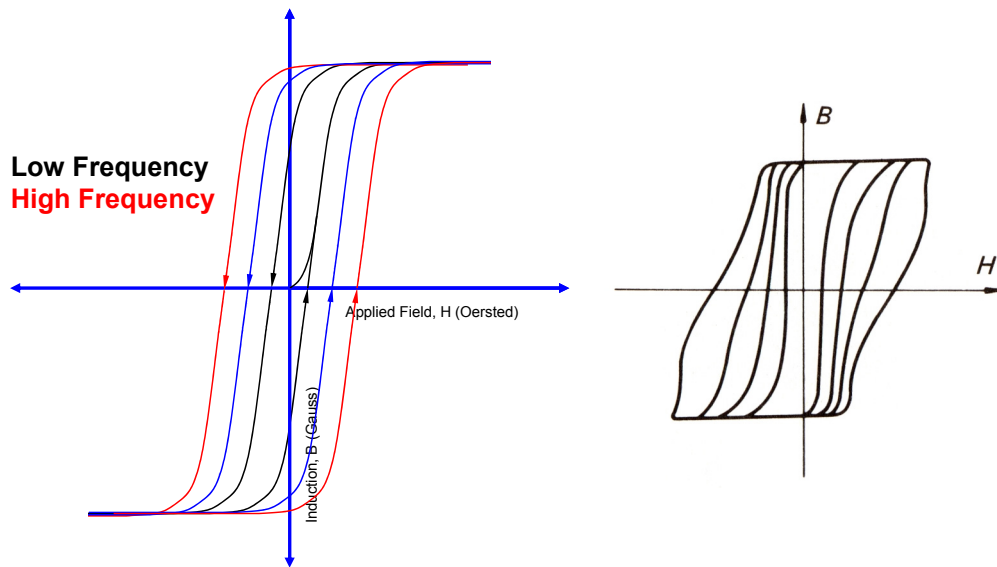

- Additionally, when the frequency of the applied field is increased, it has been found that hysteresis loss also increases ( $H_c B$  increases).
- This is manifested as an increase in the area within the hysteresis curve(s). (See the left chart).
- As the frequency continues to increase, however, another aspect of core loss begins to appear, causing not only an enlargement of the area inside the curve, but also distortion.
- This distortion is primarily due to eddy currents.

## 2: Eddy Current Loss

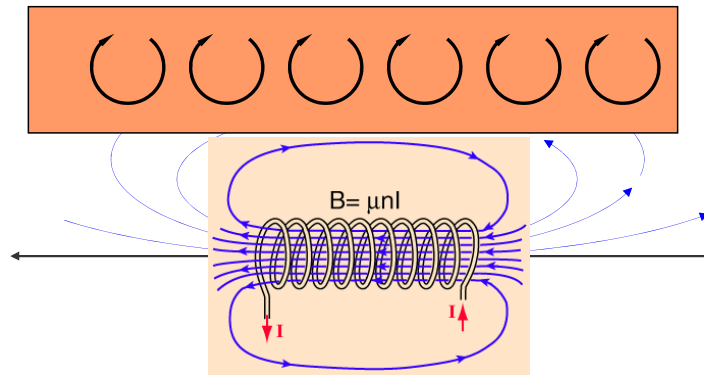

[hyperphysics.phy-astr.gsu.edu/hphys.html](http://hyperphysics.phy-astr.gsu.edu/hphys.html)



Our world touches your world every day...

- As the magnetic field alternates through a conductor, eddy currents are created in the material. These are localized currents, flowing in a closed path within the lamination.
- In accordance with Lenz's law, these currents oppose change in the field that is inducing the eddy currents.
- The creation of these currents requires energy, and therefore is a source of energy loss.
- Eddy current loss is in addition to hysteresis loss.
- It should be noted that eddy currents can occur in any conductive material including copper and aluminum - - losses are not restricted to the lamination structure.
- Incidentally, eddy currents in a non-magnetic conductor can exert significant braking effect relative to a moving magnet (forming the basis for hysteresis brakes, clutches and drives).
- A key point here is that eddy currents are caused either by a permanent magnet moving in relation to the conductive material or by a changing electromagnetic field generated by current flow in a conductor.

## 2: Eddy Current Skin Depth

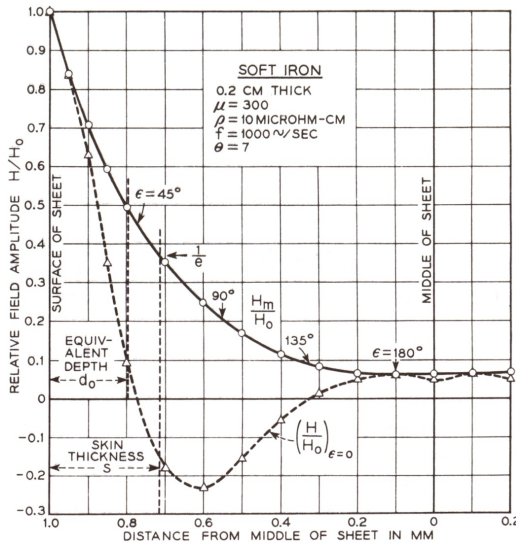

$$s = \frac{5030}{\sqrt{\mu f / (\rho \times 10^{-9})}}$$

By definition then, when  $s = 1/e$ ,  $H \sim 36.8\%$  of the surface field,  $H_0$

Ferromagnetism, R.M. Bozorth, p.771



Our world touches your world every day...

- As frequency increases, eddy currents cannot penetrate as far into the conductive material. This is known as skin effect.
- Bozorth shows the skin depth, “s”, as a function of
  - f = frequency in Hz
  - $\mu$  = permeability
  - $\rho$  = resistivity in ohm•cm



## 2: Eddy Current Skin Depth

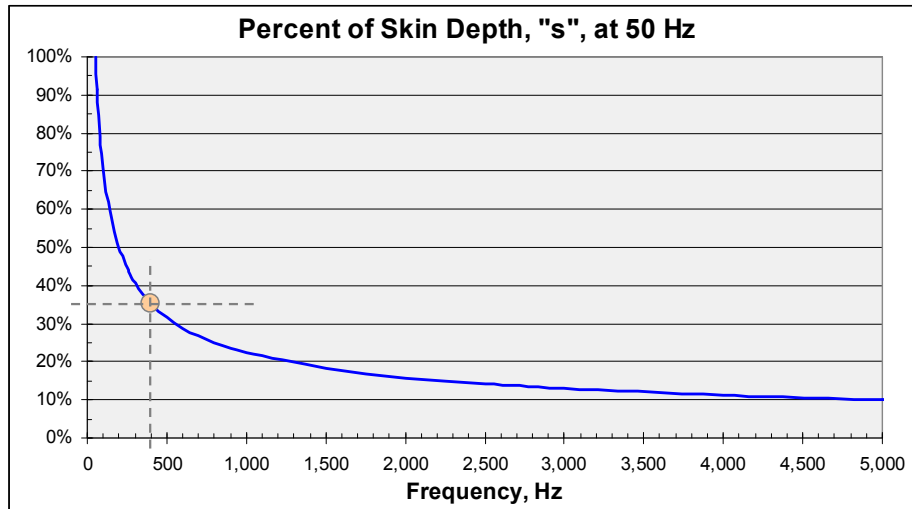

- As frequency increases eddy currents penetrate to a far lesser extent.
- Penetration depth decreases very rapidly when (switching) frequency increases above 50 Hz, reaching at 400 Hz just ~35% of the penetration depth at 50 Hz .

## 2: Eddy Current Loss

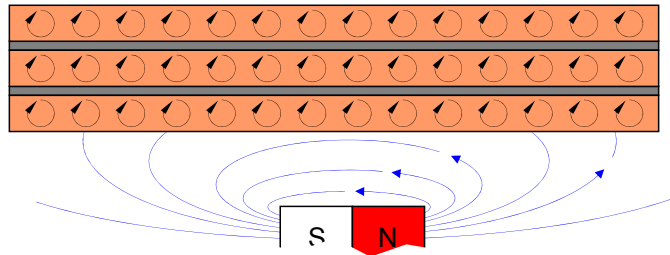

- Since eddy currents are caused by induction in conductive material, dividing the material into insulated layers breaks up the induced voltage lowering eddy current loss dramatically. That is: the sum of the losses per layer is much less than the loss for the undivided material. Induced voltage is proportional to frequency so there is greater benefit from more and thinner layers as the frequency increases.
- In working devices, eddy current loss can be lowered by reducing the thickness of the laminations and including an insulating coating between the laminations.
- Coating technology plays a major role in the ability to use soft magnetic materials at high frequencies becoming common today.
- A second method to achieve reduction in eddy current loss is use of materials with relatively higher resistivity.
- This is why ferrite cores, being a (ceramic) insulator, are used in very high frequency transformer/inductor applications. However, their saturation magnetization is so low that they are not considered useful for motors and generators.
- Another family of materials, SMC's (Soft Magnetic Composites) are of interest for frequencies above those where thin gauge Si-Fe is useful though with reduced saturation.

## 2: Si-Fe Resistivity

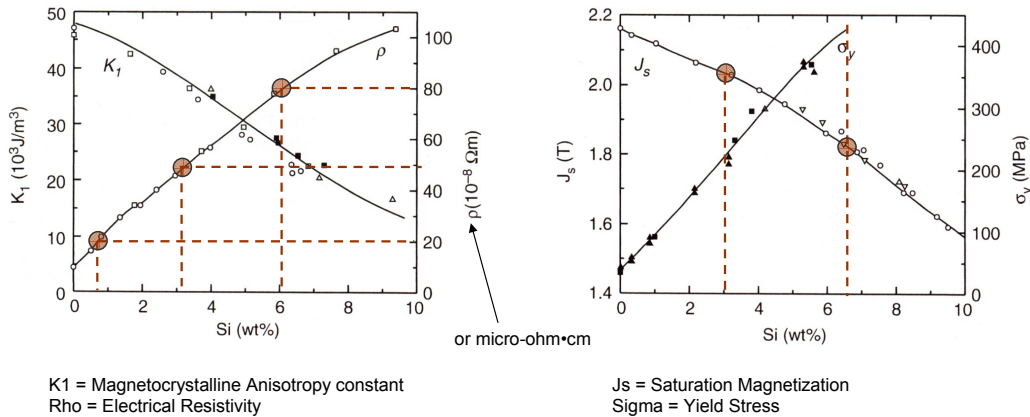

Measurement and Characterization of Magnetic Materials, Fausto Fiorillo, p.39



Our world touches your world every day...

- The electrical resistivity of 3% Silicon-iron is approximately 48 micro-ohm•cm ( $1 \text{ } \Omega \cdot \text{m} \cdot 10^{-8}$ ).
- This is about five times higher than low carbon steel.
- Saturation magnetization is reduced by the presence of silicon, dropping by about 6% with 3% Si. But since most of the lamination structure is not driven to saturation in PM motors, this small drop has minimal affect on normal use. (The pole tips of the stator structure are driven to saturation and this is where the reduction in  $M_s$  has the greatest impact).
- Use of material above 3.2% Si is limited by the difficulty in rolling it to thin strip for laminations.

## 2: Core Loss Mechanisms Silicon Steel Core Loss

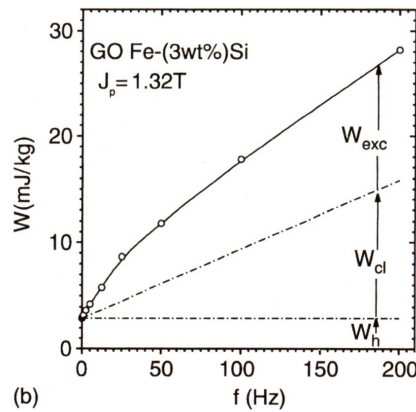

$$W = W_h + W_{cl} + W_{exc} \quad \text{Where Classical Loss is} \quad W_{cl} = \frac{\pi^2}{6} \frac{\sigma d^2 J_p^2 f}{\delta}$$

Measurement and Characterization of Magnetic Materials, Fausto Fiorillo, p.31



Our world touches your world every day...

- This chart shows measured core loss of a silicon iron lamination structure with loss components.
- In reference literature, the Hysteresis Loss ( $W_h$ ) is close to constant with frequency despite the distortion of the hysteresis loop. Resulting shifts in loss may be ascribed to the eddy currents.
- The Classical Loss ( $W_{cl}$ , including eddy current loss) is shown as proportional to frequency.
- The remaining loss is complex in mechanism, and is often referred to as: Anomalous, Residual or Excess Loss.
- Lamination thickness in this example is 0.29 mm under sinusoidal time dependence of polarization.

Delta = density

d = lamination thickness

Sigma = conductivity

$J_p$  = Peak Polarization

f = frequency

## 2: Core Loss Mechanisms Calculating Core Loss

- 1: Hysteresis
- 2: Eddy Current
- 3: Laminations
- 4: Magnetostriction
- 5: Material & Resistivity

- The measured and predicted core loss results are shown in Figure 6.32. There is a significant difference between the measured and predicted losses.
- The difference is attributed to the manufacturing techniques used. The stator laminations were welded together in order to form a core. Initially, only three welds at 120° apart were approved in order to limit the eddy current paths. During the hand winding process, the laminations were becoming loose and three more welds were added uniformly.
- The welds increased the eddy current paths, which in turn increase the total measured losses.
- Moreover, the laminations were not annealed to relief stress after cutting.
- The loss calculation formulae do not account for the manufacturing effects since they are not generic and therefore difficult to quantify accurately.

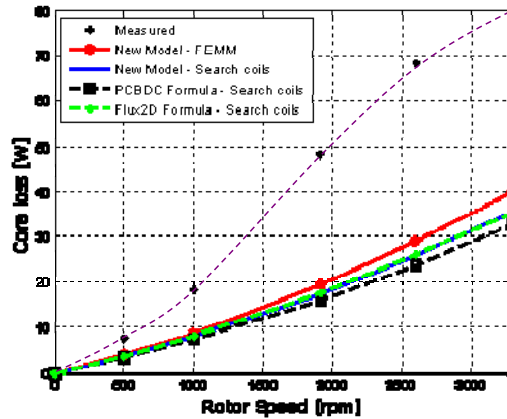

Material from reference 12



Our world touches your world every day...

- A project at Clarkson University under the direction of Professor Prag Pillay has produced computations of reasonable accuracy for core loss. See references 11 and 12.
- In this example from the final report to DOE, the very significant difference between calculated and measured core loss is attributed to manufacturing issues resulting in interlaminar conduction and demonstrates some of the difficulty in accurately describing losses in real systems.
- It also emphasizes the negative affects manufacturing can have.

### 3: Stacking Factor

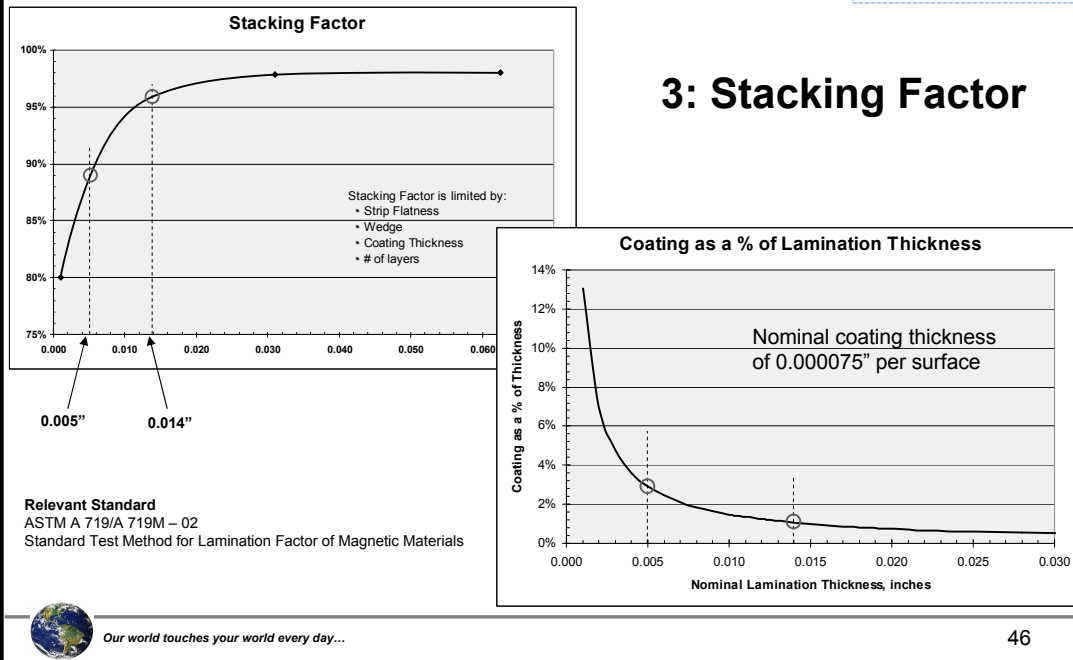

- We've seen that reducing lamination thickness can reduce core loss due to eddy currents. However, there are several drawbacks that provide practical limits to how thin the laminations may be economically made and used.
  1. **COATING:** First, the coating, although very thin (between 50 and 120 millionths of an inch), separates the laminations. We see in the chart to the right that with 0.005" laminations that a typical coating represents 3% of the total lamination thickness. Were there no other effects, the stacking factor could be a maximum of only 97%.
  2. **PHYSICAL IMPERFECTIONS:** Secondly, laminations are not physically perfect. They suffer from wedge and waffling, both contribute to irregular gaps between layers and the actual achievable stacking factor is approximately as shown in the left chart.
  3. **QUANTITY HANDLED:** Another issue is that of requirements for punching and stacking larger numbers of laminations to make up the total stack height.
  4. **PUNCH DIFFICULTY:** A 4<sup>th</sup> issue is that punching of steel becomes more difficult as the laminations become thinner. Thicknesses to 0.001" are possible, but punch difficulty increases dramatically below a lamination thickness of 0.005". At these thin gauges punching is actually a controlled tear. Punch tooling has to be of the highest quality and maintained rigorously.
- The use of thin gauge, therefore, depends upon a balance of performance with cost and technical feasibility. Switching frequencies of 400 Hz and higher or the requirement for extremely low core loss make thin gauge NGOs a requisite.

## 4: Magnetostriction

- Magnetostriction: Dimensional changes due to applied field
- Common in many soft magnetic materials
- Can contribute to core loss

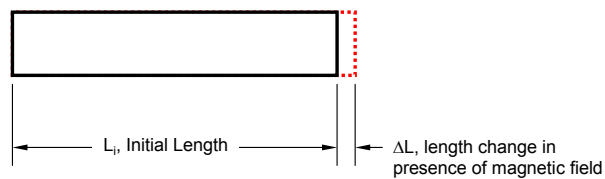

- Ferromagnetic materials experience minor dimensional change when placed in a magnetic field. This effect is called “magnetostriction.”
- The magnitude of these physical changes ( $\Delta L / L_i$ ) are small, typically a few parts per million.
- These dimensional changes absorb energy and contribute to the total core loss.
- Magnetostriction can manifest itself as audible noise, e.g. “transformer hum.”

## 4: Magnetostriction of Si-Fe

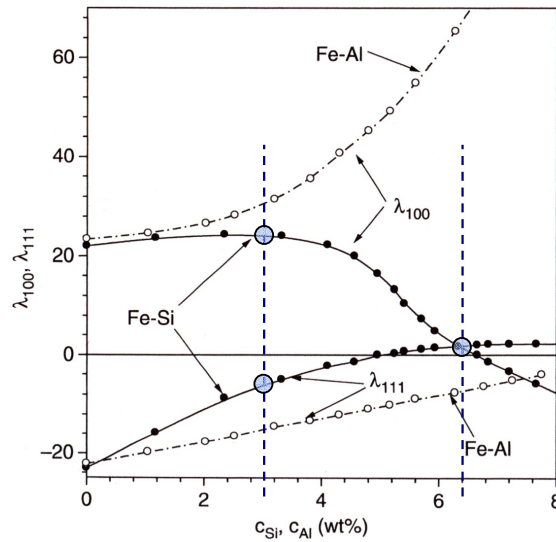

Measurement and Characterization of Magnetic Materials, Fausto Fiorillo, p.49



Our world touches your world every day...

- Magnetostriction of 3% grain oriented Si-Fe varies from about 23 in the easy axis to a negative 6 in the hard axis of orientation - - both numbers x10E-6.
- At ~6.5% Silicon, magnetostriction reaches a minimum. However, at this level of silicon, the alloy is too hard to roll successfully, especially to thin gauge.
- Similar data is available for non-oriented material in references such as: M. Enokizono, T. Suzuki, and J. D. Sievert, "Measurement of dynamic magnetostriction under rotating magnetic field," IEEE Transactions on Magnetics, Vol. 26, pp. 2067-2069, 1990.



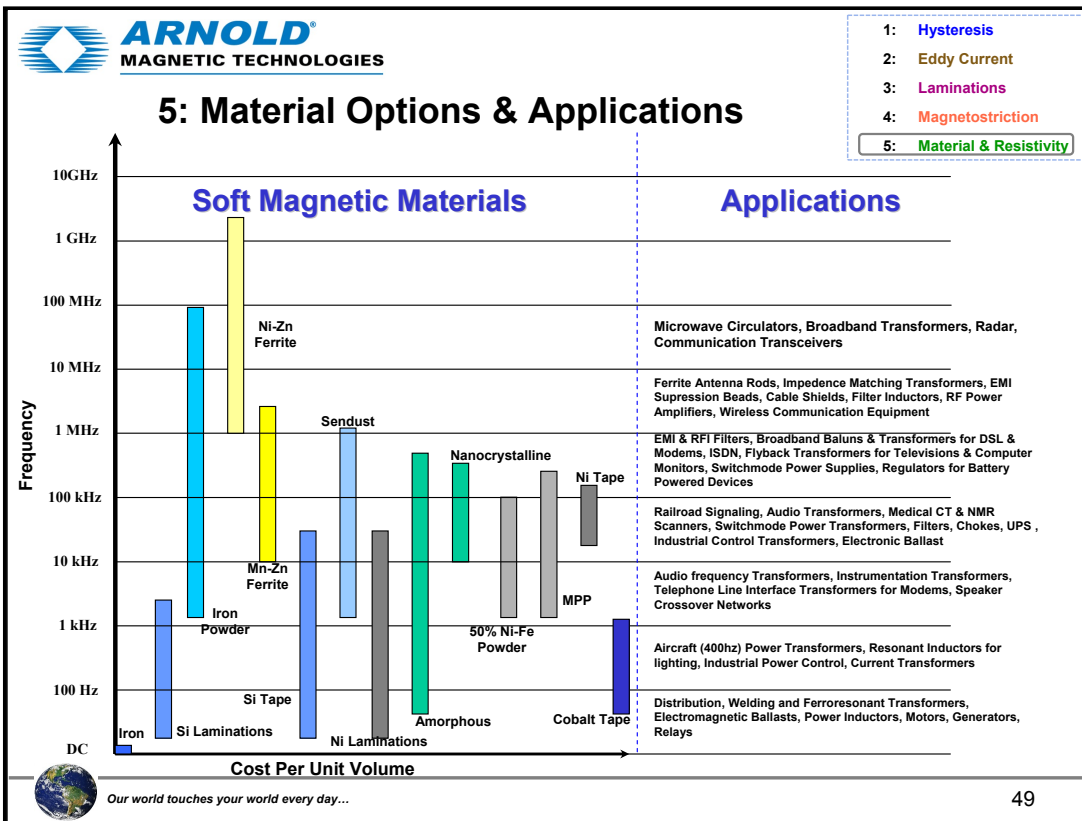

- This chart offers a comparison of soft magnetic materials as a function of cost and usable frequency range.
- Maximum use frequency depends on the operating flux density so the chart should be viewed as a general guide.
- Increasing cost per unit volume is shown from left to right. Performance improvements from a more expensive core material can provide for lower overall system cost.
- Silicon steel is used so widely because it represents a good combination of cost and performance.

## 5: Comparing Properties

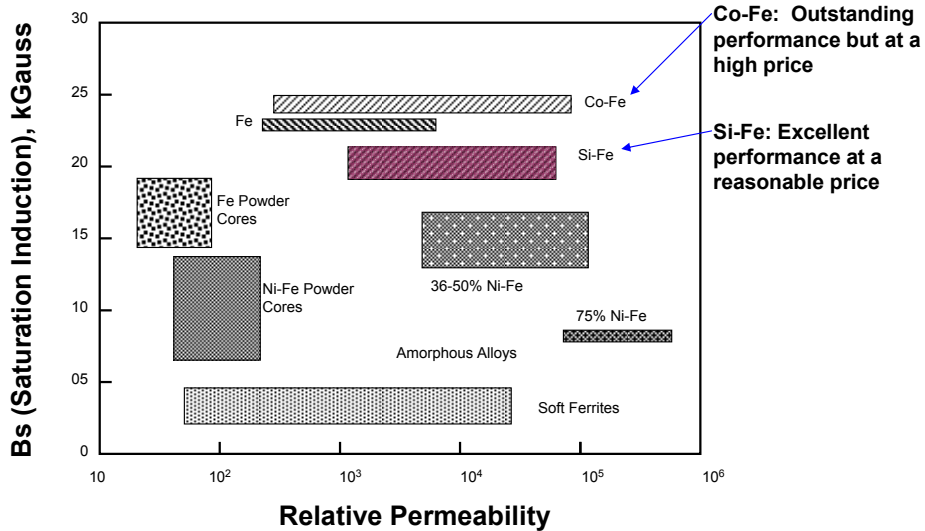

Our world touches your world every day...

- This slide plots permeability versus saturation induction for common soft magnetic materials. Both properties are usually desirable, so the best performing material shown would be the iron-cobalt alloys. While they are expensive, they are among of the best performers.
- Only slightly lower in performance is the much less costly Si-Fe material.
- Although iron can have very high permeability and high magnetic saturation, it must be pure, annealed properly and is still susceptible to hardening from mechanical working and aging.

## Agenda

- Introduction
- GOES versus NGOES
- Motor & Transformer Efficiency
- Loss Factors
- NGO Thin Gauge (Arnon)



- Thin gauge Si-Fe ( $\leq 0.007''$ , e.g. Arnon™) is particularly useful for high frequency operation to reduce eddy current loss.
- Oriented product is commonly used in high frequency or burst pulse transformer applications where the benefit of directional properties can be utilized.
- In motors, generators and rotating machinery in general, non-oriented Si-Fe is preferred since the field intersects the material at varying angles and performance benefits from material isotropy.

## Applications

- Silicon-Steel
  - Reduced eddy current losses due to material resistivity
- Thin Gauge (<0.014")
  - Reduced eddy currents at frequencies of 400 Hz and higher
- Non-Grain Oriented
  - Where the direction of magnetic flux is changing
  - Less sensitive to strain than grain oriented

Low loss Arnon materials, at 0.005 and 0.007" thicknesses, are especially useful in totally enclosed motor designs and large devices where heat cannot be easily removed.



- Three good reasons to use Arnon are:
  - Silicon steel has higher inherent resistivity
  - Thin gauge reduces eddy current loss
  - Non-oriented magnetic properties improve performance in rotating machinery
- Arnon HcB is less than 0.6 Oersteds, 8 to 15% less than competitive NGOES, resulting in lower hysteresis core loss. (Comparative measurements on same equipment during the same measurement session). Total loss is reported to be as much as 50% lower than for competitive thin gauge materials.
- This lower HcB results from very specific processing conditions during rolling and annealing.

## Hysteresis Issues

Not all the lamination structure reaches saturation

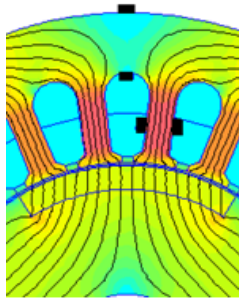

Ref. 12, page 90

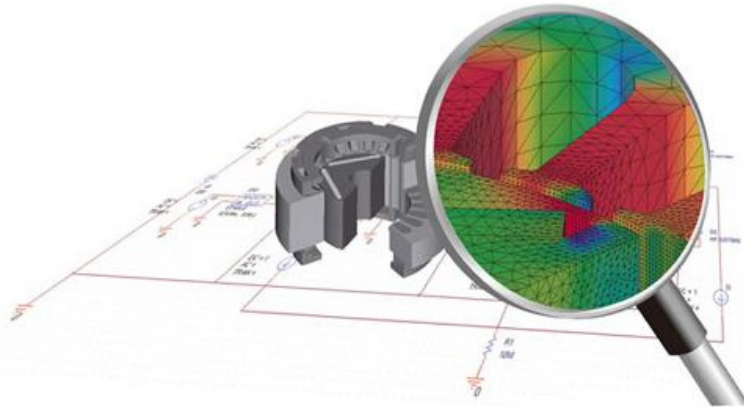

JMAG Studio from Advanced MotorTech: [www.advancedmotortech.com/jmagfea.html](http://www.advancedmotortech.com/jmagfea.html)



*Our world touches your world every day...*

53

- We've said that hysteresis loss is proportional to the area within the hysteresis loop.
- If the lamination structure is not all saturated, then portions will be operating on a minor loop.

## Hysteresis Curve - Minor Loops

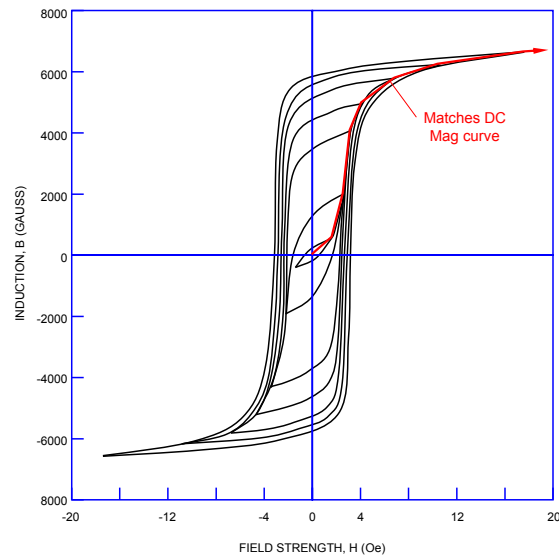

*Our world touches your world every day...*

- This is a series of super-imposed minor hysteresis curves. It can be clearly seen that the induction response differs greatly depending upon the level of applied field (H).
- The energy loss will be proportional to the area within the specific minor loop within the lamination material.
- Since not all the material will see the same externally applied field, there will be unequal energy loss from place to place within the lamination structure.
- The more square-loop the material, the greater the sensitivity to small changes in applied field.

## Hysteresis Curve - Minor Loops

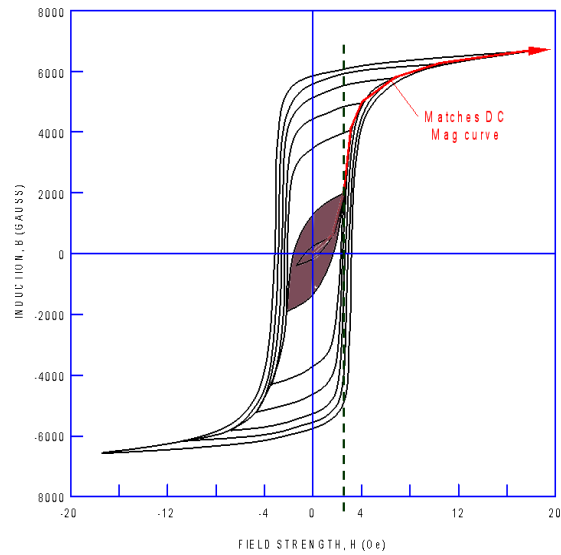

Our world touches your world every day...

- The more square loop the material, the greater the sensitivity to small changes in applied field as we see in this series of illustrations.
- The dashed green line marks the applied field, H.

## Hysteresis Curve - Minor Loops

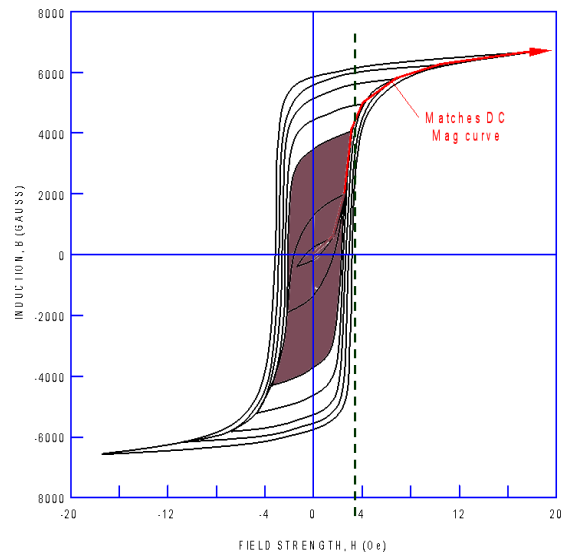

Our world touches your world every day...



## Hysteresis Curve - Minor Loops

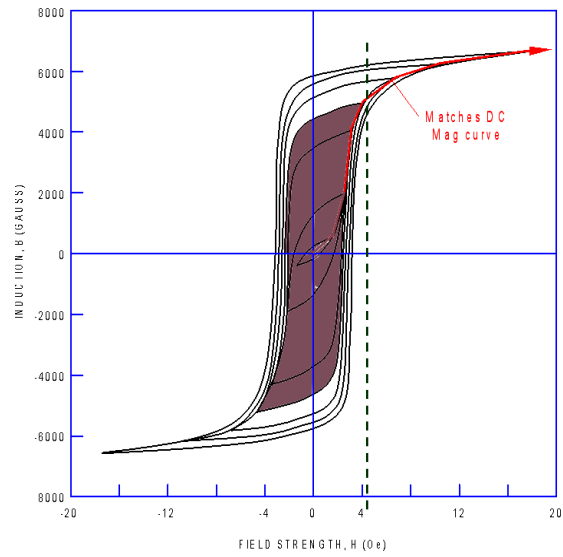

Our world touches your world every day...

## Hysteresis Curve - Minor Loops

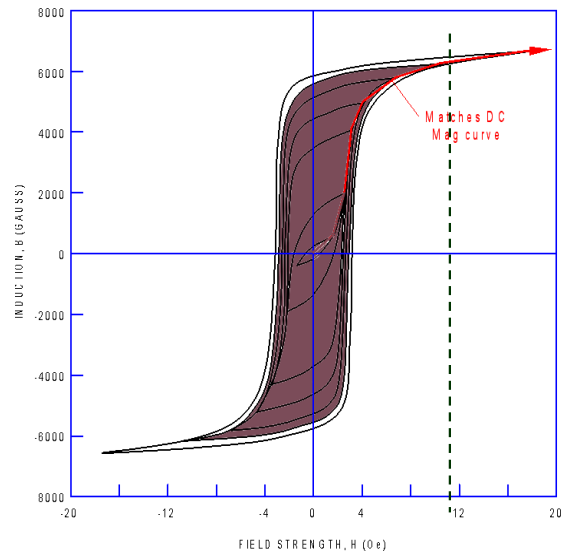

Our world touches your world every day...

- It is apparent that initially large changes in loss occur.
- Then, as the material nears saturation, large changes in applied field are required to make noticeable changes in loss.

## DC Measurements Comparison of Arnon and Alternate Material

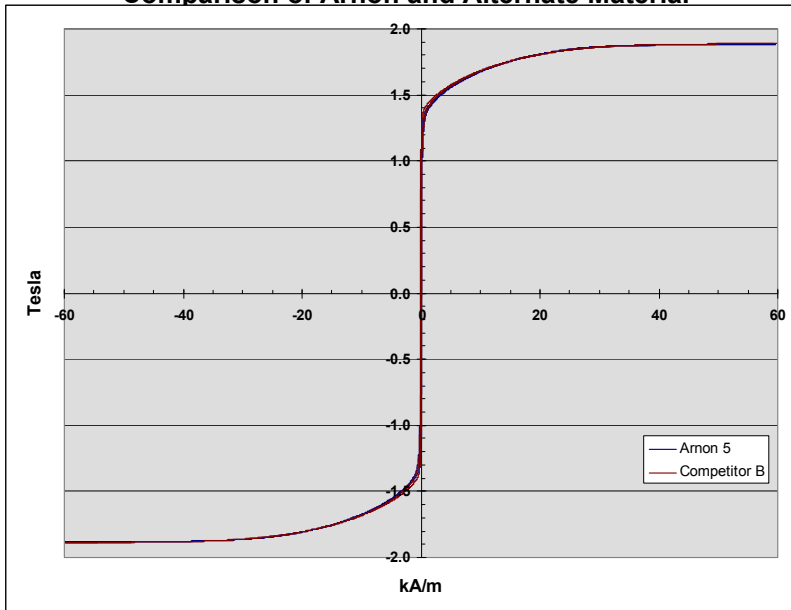

*Our world touches your world every day...*

- Recent measurements of Arnon 5 and 7 product versus similar commercial products are shown in these DC hysteresis loops. (Data from Magnet Physics, Dr. Steingroever).
- At this scale, there is very little visual difference in performance.

## Core Loss as a Function of Frequency

Arnold 0.005" Ring, 9294MPS08

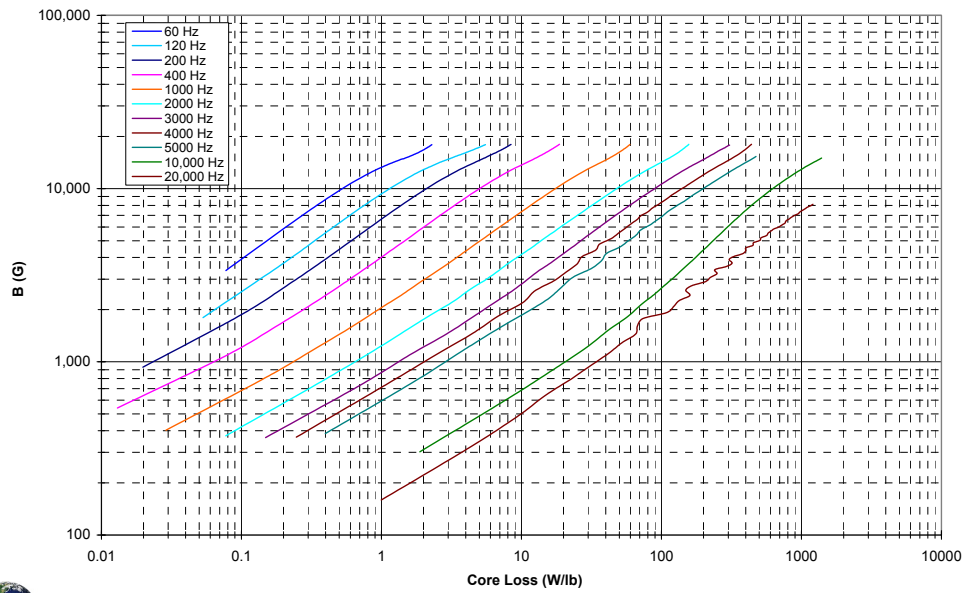

Our world touches your world every day...

- Core Loss at various frequencies can be measured.
- This chart is for Arnon 5 and for frequencies between 60 and 20,000 Hz.

### Core Loss: Comparison of 5 mil by Product Source

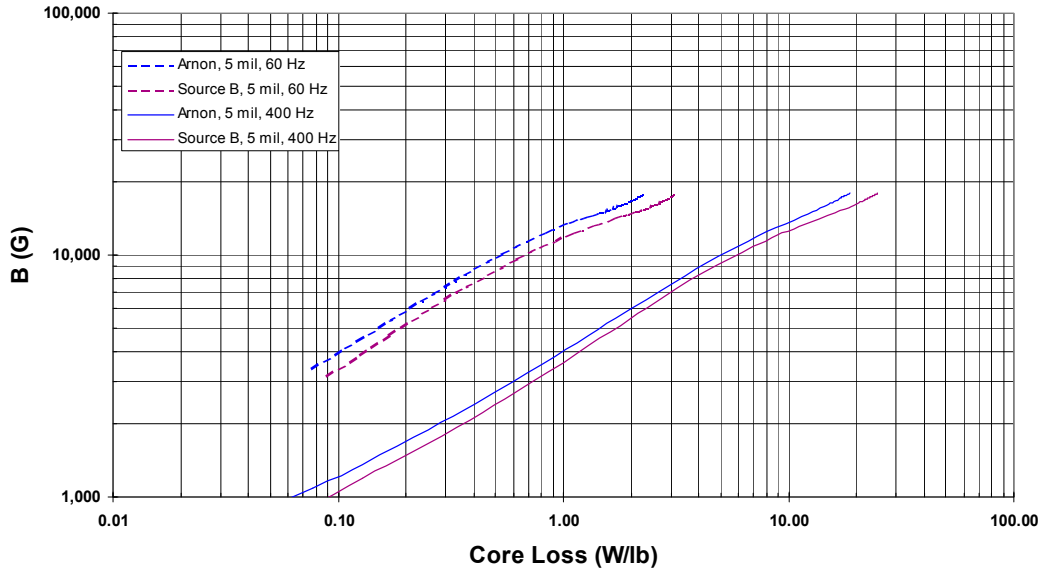

Our world touches your world every day...

- A comparison between Arnol 5 and the source B 5 mil material is shown here at 2 frequencies to keep the chart simple.

## DC Measurements

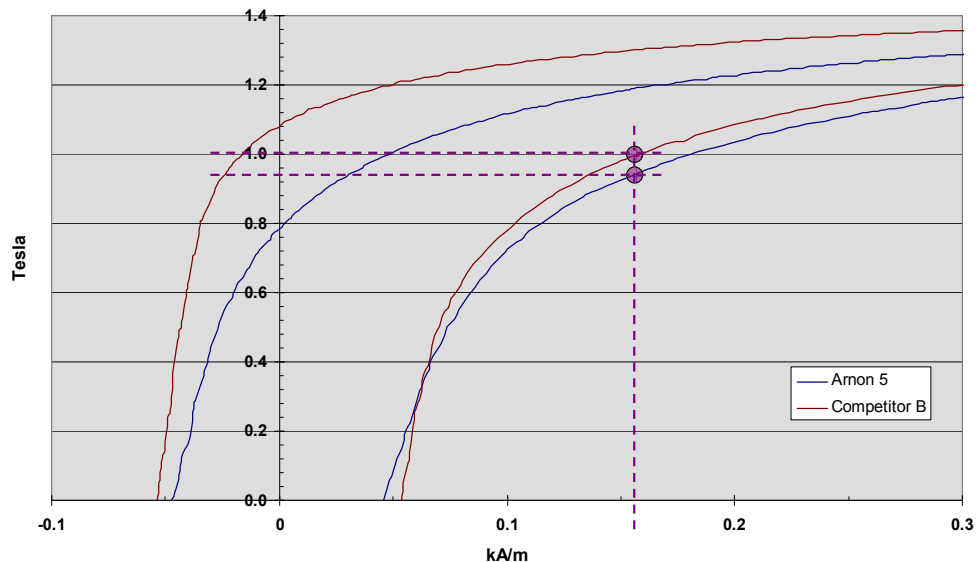

Our world touches your world every day...

62

- When we expand the hysteresis data and focus on the 1<sup>st</sup> and 2<sup>nd</sup> quadrant, what we see is the difference in “B” achieved at any level of “H”.
- Specifically, The applied field to drive the competitor material to B=1.0 Tesla only drives the Arnon to 0.93 Tesla.
- At the pole tips both materials will be driven to saturation. However, at locations of lower applied field, the Arnon will not be driven to as high a “B.”
- While we could integrate within the curves to calculate the difference in hysteresis loss, it is easier to simply measure it.

## Comparative Core Loss, 5 mil Si-Fe

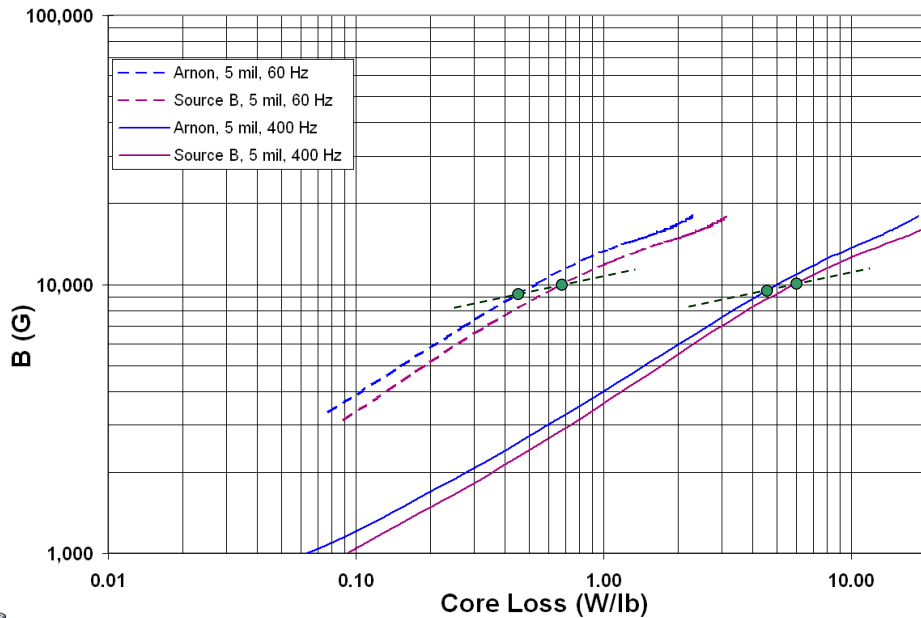

Our world touches your world every day...

63

- By comparing the core loss at the level of “B” achieved by the applied field in the device, we see a core loss difference at 60 Hz of 0.45 (Arnon) versus 0.68 (Source B). Source B is 50% higher than the Arnon when driven by the same “H” field.
- At 400Hz, the difference is 0.47 (Arnon) versus 0.60 (Source B). Source B is 28% higher.
- This confirms anecdotal customer information on the relative performance.
- And it confirms the importance of hysteresis curve shape as well as saturation magnetization.

### Arnon 5 and 7 Core Loss Non-Grain Oriented, 5 and 7 mil Si-Fe

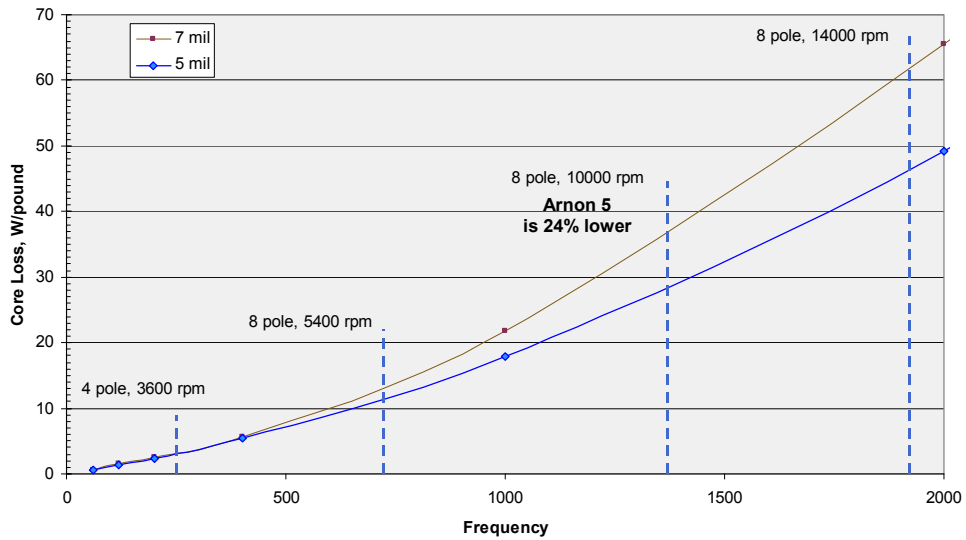

Our world touches your world every day...

- Below 400 Hz, core loss for both Arnon 5 and Arnon 7 are similarly low.
- Above 400 Hz, Arnon becomes increasingly more advantageous.
- Several example frequencies are shown here emphasizing that higher RPM and greater number of poles drives the switching frequency higher.



## An Example: Small Motor Comparison

### Existing Design

#### 5 HP (Motor + Gearbox)

- Torque Varies
- Speed adjusted with Gearbox, not motor
- Efficiency Varies
- Max Efficiency for Speed range 72%
- Overall Weight: 266lbs



### New 5+ HP EVT Motor

#### (Direct Drive)

- Consistent Torque
- Speed adjusted at motor, precisely
- Efficiency remains consistent
- Max Efficiency for Speed range 97%
- Overall Weight: 200lbs



Courtesy EVT LLC, [www.evtllc.com](http://www.evtllc.com)



*Our world touches your world every day...*

65

- In this example, the challenge is to replace an open type motor and gear box with a **totally sealed** motor without gear box while improving on the linearity of torque and raising the efficiency.

## Efficiency Curve – Predicted versus Actual

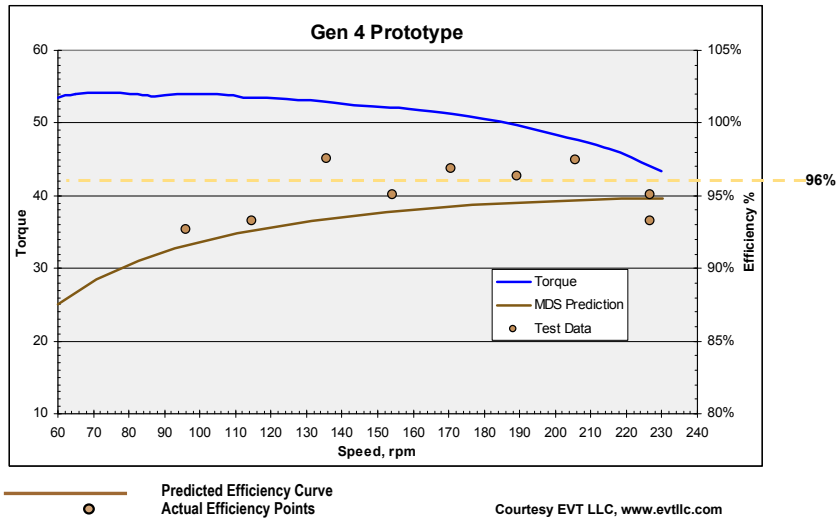

(Predicted Efficiency curve as illustrated by Motor Development Software, University of Glasgow)



Our world touches your world every day...

- Data is from 80 to 230 output rpm.
- The torque curve is exceptionally flat, especially at the lower rpm's.
- Efficiency averages 96% over more than half the speed range and peaks between 97 and 98%
- This drive, which uses Arnon 7, is totally enclosed with no cooling and experiences ~10 °C rise above ambient in continuous operation.

## Very Thin Gauge Si-Fe (Grain-Oriented)

NGOES is used for rotating machinery.  
GOES (Grain oriented electrical steel) is used in transformers and inductors.

Table 1. Recommended Grain Oriented Silicon Steel Thicknesses for Various Operating Frequencies

Frequency	Recommended Thickness	Approximate Induction for 300 mW/cc 18 W/lb, 40 W/kg*
400 Hz	4 mil or 6 mil	15,000 G*
1 kHz	4 mil or 6 mil	10,000 G
2 kHz	2 mil	6,000 G
5 kHz	1 mil	3,000 G

\* For reference only. Based on Arnold C-core data records. (Arnold no longer manufactures C-cores). At 400 Hz, magnetizing current limits the maximum flux density.

Table 2. Recommended Grain Oriented Silicon Steel Thicknesses for High-Power Pulse Operating Conditions\*

Pulse Width	Recommended Thickness	Pulses per Second
2 to 1000 microseconds	4 mil or 6 mil (D-U, U-I, L-L Laminations)	to 1000
0.25 to 2 microseconds	1 mil or 2 mil (C-core)	to 1000

\* For reference only. Based on Arnold C-core data records. (Arnold no longer manufactures C-cores). At 400 Hz, magnetizing current limits the maximum flux density.



Our world touches your world every day...

- Arnold also produces **grain oriented** Si-Fe at 1, 2, 4, and 6 mil, primarily for use in laminated and wound high frequency transformers and chokes.
- Although Grain-Oriented is not normally used for rotating machinery, at least one recent design incorporates this material in a segmented stator design - - segmented to allow alignment of the laminations more closely to the applied field.

## Summary

- Higher efficiency is being driven by both economic and political forces
- Si-Fe offers performance improvements over steel and cost reduction over Co-Fe
- Thin gage Si-Fe provides efficiency improvements with thinner gage increasingly advantageous with higher frequencies
- The magnetic loop shape of Arnon provides substantially reduced hysteresis loss in rotating machinery.



## References

1. Ferromagnetism, Richard M. Bozorth, IEEE Press, 1993
2. Measurement and Characterization of Magnetic Materials, Fausto Fiorillo, Elsevier Academic Press, 2004
3. Handbook of Small Electric Motors, William H. Yeadon and Alan W. Yeadon, McGraw-Hill, 2001
4. Handbook of Electromagnetic Materials, Perambur S. Neelakanta, CRC Press, 1995
5. Electrical Materials Handbook, Allegheny Ludlum Steel Corp., 1961
6. Handbook of transformer Design & Applications, William M. Flanagan, McGraw-Hill, 1992
7. Applications of Magnetism, J.K. Watson, Storter Printing, 1985
8. Proto Laminations Website ([www.protolam.com](http://www.protolam.com))
9. Lamination Steels CD-ROM, EMERF
10. Silicon Steels and Their Applications ([www.key-to-steel.com/DE/DE/Articles/Art101.htm](http://www.key-to-steel.com/DE/DE/Articles/Art101.htm))
11. An Improved Formula for Lamination Core Loss Calculations in Machines Operating with High Frequency and High Flux Density Excitation, IEEE, 0-7803-7420-7/02, Yicheng Chen, Pragasen Pillay
12. Improved Design of Motors for Increased Efficiency in Residential and Commercial Buildings, 2008 Final Report to U.S. Department of Energy, Building Technologies Program Topical Report, Pragasen Pillay
13. Wikipedia ([www.wikipedia.org](http://www.wikipedia.org))



- All of these were useful, but the three in dark blue were excellent.

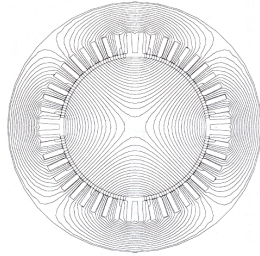

**Thank you !**

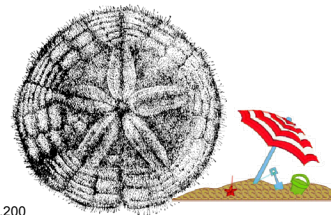

FEA from Permanent Magnet Motor Technology: Design and Applications, Jacek Gieras and Mitchell Wing, p.200



*Our world touches your world every day...*